Table of Contents

Introduction to Diesel Technology Workbook

Subject	Page
BMW Diesel Technology	9
Why did the diesels disappear from the US Market?	10
Customer Perception	10
Summary	10
Why are diesels making a comeback in the US?	11
Efficient Dynamics	12
New Diesel Engine	14
Engine Specifications	14
Diesel Fundamental Principles	16
Diesel Engine to Gasoline Engine Comparison	17
Combustion Cycle Comparison	18
Diesel Combustion Cycle	19
Diesel Fuel Properties	20
Diesel Fuel	20
Diesel Fuel Types	21
Winter Fuel	22
Cetane Rating	22
Cold Weather Properties	23
Cloud Point	23
Pour Point	23
Cold Filter Plugging Point (CFPP)	24
Cold Climate Measures	24
Diesel Fuel Additives	24
Dyes	24
Microbes	25

Table of Contents

Subject	Page
Sulfur Content	25
Lubricity	26
Grades	26
Off Road Use	26
Flash Point and Auto-ignition	27
Fuel Mixing	27
Diesel Oil	28
Engine Mechanical	40
Engine Construction Comparison	41
Pistons, Crankshaft and Connecting Rods	42
Piston - Diesel Engine	42
Piston - Gasoline Engine	42
Cylinder Head and Valvetrain	44
Camshafts	45
Lubrication System	46
From Oil Pan to Oil Pump	47
Oil Pump	48
Functional Principle	48
Pressure Relief Valve	49
Oil Filtering	50
Non-return Valve	50
Filter Bypass Valve	50
Heat Exchanger Bypass Valve	50
Engine Oil Cooling	51
Oil-to-air Heat Exchanger	51
Oil-to-coolant Heat Exchanger	51
Oil Spray Nozzles	51
Intake System Overview	53

Table of Contents

Subject	Page
Diesel Engine Management	70
Engine Control Module (DDE)	71
DDE I-P-O Chart (Typical)	72
Sensors and Actuators	74
Sensors	74
Actuators	74
Switches	74
Relays	74
Interfaces	74
Electro-pneumatic Pressure Converter (EPDW)	74
Electric Changeover Valve (EUV)	74
Diesel Fuel Systems	76
Distributor Type Diesel Injection	77
Common Rail Fuel Injection	78
Common Rail System Components	79
High Pressure Fuel Pump	79
Functional Principle	80
Two-actuator Concept	81
Advantages	81
Rail Pressure Sensor	82
Pressure Control Valve	82
Accumulator (Fuel Rail)	82
High Pressure Fuel Lines	82
Fuel Injectors	83
Piezo-Electric Principles	84
Piezo Technology	84

Table of Contents

Subject	Page
Fuel Injector Operation85
Leakage Oil85
Low Pressure System86
Function86
Fuel Supply System Overview87
EKP Control Module88
Fuel Filter Heater89
Functional Principle89
Diesel Air Management92
Air Intake System92
Air Intake System Overview93
Intake Silencer/Air Filter94
M57D30T2 Engine94
Unfiltered Air Duct94
Intercooler95
Throttle Valve96
Swirl Flaps97
Swirl Flap Operation97
Effects of Swirl Flap Malfunctions97
Hot-film Air Mass Meter (HFM 6.4)98
Functional Principle98
Measurement Method98
Charge Air Temperature Sensor	100
Boost Pressure Sensor	100
Vacuum System	101
Vacuum Pump	102

Table of Contents

Subject	Page
Non-return Valve	103
Non-return Valve, Brake Booster	103
Vacuum Distributor	104
Vacuum Reservoir	104
Electro-pneumatic Pressure Converter (EPDW)	105
Electric Changeover Valve	106
Exhaust Turbocharger	108
Twin Turbocharging	108
High Pressure Stage	109
Low Pressure Stage	109
Turbine Control Valve	109
Compressor Bypass Valve	109
Wastegate	109
Two-Stage Turbocharging Function	110
Turbine Control Valve	110
Compressor Bypass Valve	110
Wastegate	110
Lower Engine Speed Range (up to 1500 rpm)	111
Medium Engine Speed Range (from 1500 to 3250 rpm)	111
Upper Engine Speed Range (from 3250 to 4200 rpm)	112
Nominal Engine Speed Range (as from 4200 rpm)	112
Diesel Emission Controls	114
Combustion By-products	115
Hydrocarbons (HC)	115
Effects of HC Emissions	115
Carbon Monoxide	116

Table of Contents

Subject	Page
Effects of CO Emissions	116
Oxides of Nitrogen (NO _x)	117
Effects of NO _x Emissions	117
Particulate Matter	118
Carbon Dioxide	119
Diesel Emission Control Systems	120
Engine Measures to Reduce Emissions	121
Injection Strategy	122
Multiple Injection	122
Charge Air Cooling	123
Exhaust Gas Recirculation (EGR)	123
EGR Control	124
EGR Cooling	124
Exhaust After-treatment	125
Diesel Oxidation Catalyst (DOC)	125
Reduction of Unwanted Emissions	126
Diesel Particulate Filter	126
Function of the DPF	126
Filter Regeneration	127
Sensors - Exhaust System	128
Exhaust Temperature Sensor	128
Version with Two Exhaust Temperature Sensors	128
Exhaust System with One Exhaust Temperature Sensor	128
Oxygen Sensor	129
Exhaust System Layout (Typical)	130
Selective Catalytic Reduction (SCR)	131
Diesel Exhaust Fluid	131

Table of Contents

Subject	Page
Diesel Auxiliary Systems	132
Glow Plug System	132
Glow Plug System Function	133
Diesel Starter	134
Vibration Reduction	135
Engine Mount Control	135
Engine Mount Function	135

Introduction to Diesel Technology Workbook

Model: All with Diesel Engine

Production: From Start of Production

OBJECTIVES

After completion of this module you will be able to:

- Understand fundamental diesel principles
- Understand the fundamental differences between gasoline and diesel engines
- Understand the required service procedures on diesel engines
- Understand diesel fuel injection and engine management systems
- Understand diesel exhaust emissions and emission control systems

BMW Diesel Technology

For the first time since 1986, BMW will have a “Diesel powered” vehicle in U.S. market. The previous diesel engine in use was the M21D24. The M21 was only available in the 524td (E28).

This engine featured state of the art technology which included turbocharging and the latest Bosch diesel fuel injection. At the time, the M21 was considered to be one of the best performing turbo diesel engines in the world.



However, diesel engines were not widely accepted in the U.S. market. This was due to the relatively cheap prices of gasoline and the negative perceptions associated with diesel engines.

Most of the available diesel engines available in the market at the time were not very appealing to the average customer. Engine noise, fuel and exhaust odors along with soot emissions contributed to a negative image of diesel engines. Also, diesel engines were somewhat sluggish as compared to their gasoline fueled counterparts.

One of the positive attributes of diesel engines was fuel economy and overall efficiency. This was one area in which the diesel engine excelled.

Even with all of the positive aspects of diesel ownership evident, most customers did not widely embrace the diesel experience. As a result, the 524td was discontinued in 1986.

However, since 1986, BMW continued to refine and develop diesel engines for other markets. The high price of available fuel in other countries drove customers to diesels at a higher rate than in the U.S. market.

To meet the demand for diesel engines, BMW improved on the 6-cylinder diesel engine. In addition to the 6-cylinder, 4 and 8 cylinder diesels were developed for other markets.

Over the last 20 years, BMW has continued to improve on the diesel engine and reduce the “undesirable” aspects of diesel ownership. Power output has been increased, while reducing noise and emissions. In European markets, diesel vehicles now account for more than 50% of newly registered vehicles. Sales of BMW diesel vehicles account for more than 60% of new vehicle purchases in the European markets.

In the fall of 2008, BMW will re-introduce diesel vehicles to the US market in the form of a 6-cylinder, twin turbo engine featuring the latest in common rail fuel injection technology.

The new engine will be referred to as the M57TU2 TOP. The new 6-cylinder diesel engine from BMW will offer the same high level of performance that is expected from BMW drivers.

In short, the new diesel vehicles will fit well into the concept of “Efficient Dynamics”. This concept ensures the highest reduction in CO₂ emissions without a compromise in performance.

The new diesel BMW’s offer two features which, together, are not usually associated with diesel engines or spoken in the same sentence - Performance and Efficiency.

Why did the diesels disappear from the US Market?

In the US market, diesel vehicles have not had much success over the last 20 years. Most of this is due to customer perception and the relatively low cost of gasoline.

Although many people feel that the price of gasoline is high in the US, other parts of the world pay much higher prices due to the additional taxes. In comparison, fuel prices in Europe are twice as high as in the US. This accounts for the difference in the overall acceptance of diesel between the US and European markets.

In the early 1980's the price of gasoline was increasing, but was not enough of a motivating factor to convert customers to diesel vehicles in sufficient numbers. Diesel engines did not offer enough of an alternative to gasoline engines because they did not perform as well. They were sluggish and did not deliver much in the way of dynamic performance.

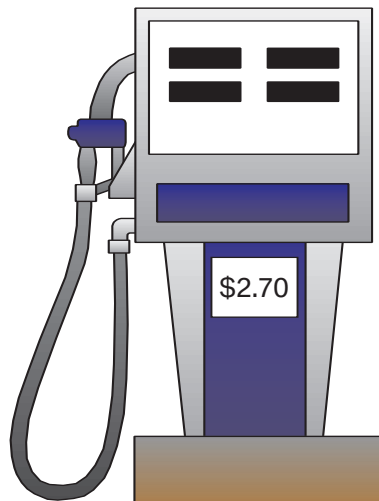

U.S. Average Price
for Diesel Fuel
(summer 2007)

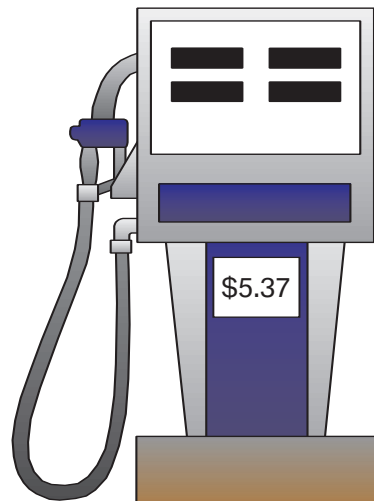

European Average
Price for Diesel Fuel
(summer 2007)

Customer Perception

More than 20 years ago, the diesel vehicles available in the US market did not have the advantages of today's technology. By the time BMW brought the 524td to the US, the diesel market had already declined due to the less than desirable aspects of some of the competitive products available at the time.

Much of the negative perception of diesel vehicles centered around the odors from the exhaust and fuel itself. Also, diesel exhaust contained a high amount of soot which contributed to the dirty image of diesel vehicles.

The combustion process in early diesel engines was abrupt and created a lot of additional engine noise as well. This noise gave the diesel passenger car more of a "truck-like" impression to potential customers.

■ Summary

The absence of diesel powered passenger cars in the US can be summed up in the following areas:

- Engine noise
- Exhaust odors
- Dirty, soot emissions excessive
- Fuel smell
- Low power, lack of performance, sluggish
- Cold starting performance
- High emissions of NO_x

The above mentioned issues on the diesel engine have been resolved with the advancements in engine, emissions and fuel injection technology. In the subsequent pages, the latest diesel technology will be reviewed and explained in more detail.

Why are diesels making a comeback in the US?

Given the current global concerns, BMW diesel engines are a logical choice for customers looking for economy and performance. There are other alternatively fueled vehicles on the market today, but BMW offers a true “premium” experience with the diesel engine.

Everyday, the news is filled with articles on global warming and the need for a reduction in CO₂ emissions. There are continuing discussions on the need to reduce our dependence on foreign oil and to look for alternatives.



BMW is offering alternatives in the form of Hydrogen power, future Hybrid technology and now “Diesel Power” for the Ultimate Driving Machine.

In the last 20 years, BMW has developed “cutting edge” diesel engines which have gone relatively unnoticed in the US market. This is due, primarily, to the perception of the customer.

Past negative experiences or a lack of overall diesel knowledge have kept customers from experiencing diesel technology.

The lack of available diesel vehicles in the US has only served to keep interest at a minimum.

Today, more and more customers are becoming aware of diesels and the potential benefits of ownership. BMW offers all of these benefits with the addition of performance and the usual value that customers expect.

The new BMW engines benefit from the latest “common rail” fuel injection systems. These systems are high pressure, precision injection systems which are capable of having multiple injection events. These systems contribute to the increased performance and reduction of emissions.

As compared to the M21 engine from 1983, the latest BMW diesel vehicles have improved in the following areas:

- Engine noise has been reduced by engine design and fuel injection strategy. Additional engine soundproofing also contributes to the reduction in noise.
- Particulate emissions have also been reduced by 99% as compared to the M21 engine. This was accomplished by injection strategy and by the new diesel particulate filter (DPF).
- Fuel consumption has been reduced by 20%.
- Torque output has been increased by 160% through the use of the innovative twin-turbocharger design.
- Horsepower has been increased by more than 135%.
- NO_x is further reduced by the diesel oxidation catalyst, EGR valve and by the new SCR system.
- Other engine modifications also contribute greatly to the modern BMW diesel engine.

In short, it’s time to bring the diesel back.

Efficient Dynamics

Today, much of the focus from the automotive industry centers around fuel efficiency and concern for the environment through the reduction in CO₂ output. Usually, the words “efficient” and “dynamic” are not usually adjectives used to describe the same vehicle. However, this is not the case when describing vehicles from BMW.

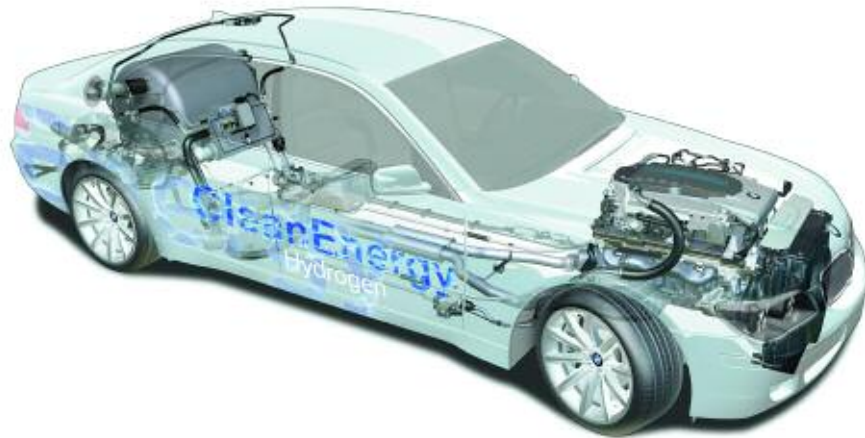

Many of our customers are familiar with our most famous tag line “The Ultimate Driving Machine” and they won’t settle for anything less. It is a huge challenge to not only meet performance expectations, but to maintain overall efficiency and environmental responsibility.

BMW has been able to meet and exceed these goals through the latest innovations in engine technology. Systems such as VANOS, Valvetronic, lightweight engine construction and the latest in engine management have contributed to increasing performance while improving fuel economy.

One of the first vehicles to be associated with the “Efficient Dynamics” strategy was the BMW Hydrogen 7. This vehicle is also the flagship for BMW’s “Clean Energy” concepts. The new BMW Hydrogen 7-series is “bivalent” which means it can be run on both gasoline and hydrogen.

The “Hydrogen 7” has a V-12 internal combustion engine which takes advantage of one of the most plentiful and “eco-friendly” resources on Earth - Hydrogen. Using hydrogen as an automotive fuel is not an entirely new concept for BMW. These ideas have been in development by BMW since the 1970’s.

It’s important to note, that the new Hydrogen 7 is not only a concept vehicle, but is a production vehicle which is currently for sale. Although it is not currently available in the US, is being tested here and will be for sale in other markets.



BMW's dedication to Efficient Dynamics does not rest on a single vehicle, but rather is evident on many other new products and technologies.

For example, BMW gasoline engines have had many fuel saving innovations for many years. Recently, Valvetronic technology has allowed BMW vehicles to gain "best-in-class" fuel economy across the model line.

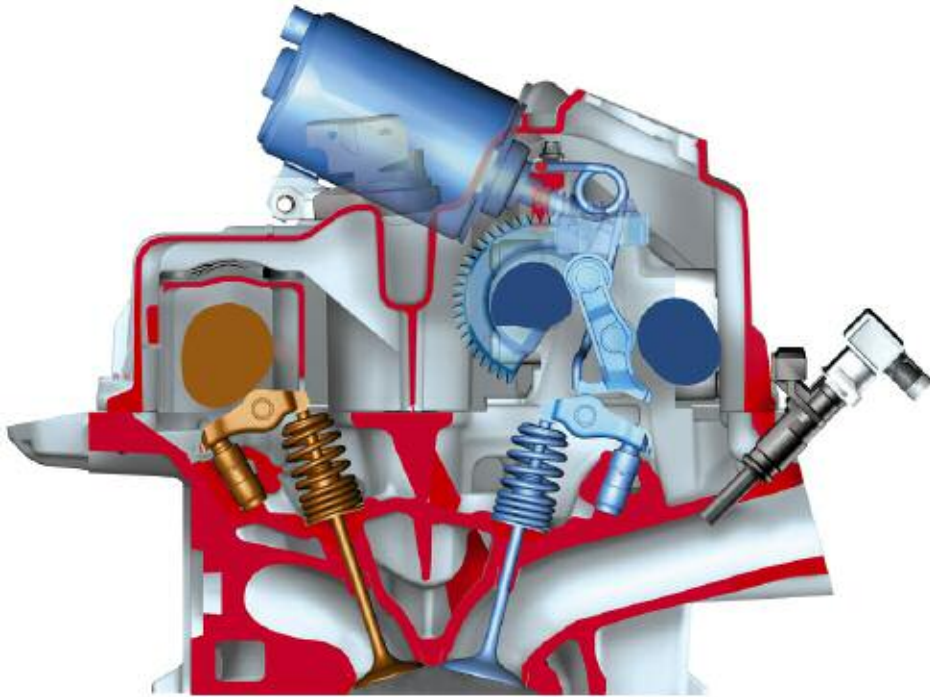

Some of the other engine innovations include high-precision direct fuel injection for gasoline engines. The HPI system allows the N54 engine to maintain maximum performance and astounding fuel economy in a 300 hp engine.

To complement all of the engine technology currently in use, BMW will be adding diesel powered BMW's to the model line by the end of 2008. Besides the obvious fuel saving advantages of diesel engines, there are many performance related aspects of this new technology.

The new 335d for the U.S. market is expected to accelerate from 0-62 mph in 6.2 seconds while achieving a fuel economy of 23/36 mpg (city/highway provisional data). The same engine in the X5 can accelerate to 62 mph in 7.2 seconds while offering fuel economy figures of 19/26 mpg (city/highway provisional data).

With its carbon emissions down 10% - 20% from comparable gasoline vehicles, and near-elimination of both smoke and NOx emissions, BMW Advanced Diesels will be every bit as clean as CARB-legal gasoline engines when they are introduced in the US in 2008.



Both diesel and gasoline engines from BMW have taken home the prestigious "International Engine of the Year Award" several times. Now, one of these award-winning diesel engines will be available in 2009 models.

New Diesel Engine

Some of the features on the M57TU2 TOP include:

- A horsepower rating of 265 hp
- 425 lb-ft (580 Nm) of torque
- 3rd Generation common rail fuel injection (1600 bar) with Direct Injection
- Piezo-electric injectors
- Two-stage turbocharging with intercooler
- Lightweight aluminum alloy crankcase
- Particulate filter (DPF)
- EGR system with EGR cooler
- Diesel Oxidation Catalyst
- Digital Diesel Electronic (DDE)
- Selective Catalytic Reduction (SCR) System

In addition to the features listed above, the new 6-cylinder diesel includes fuel heating system and a new “fast start” glow plug system to ensure optimum cold weather starting.

Note: In accordance with the current engine numbering system, the M57TU2 TOP engine will be known officially as the M57D30T2.

Engine Specifications



M57TU2 TOP/M57D30T2	
Number of Cylinders	6
Bore	84
Stroke	90
Displacement	2993 cm ³
Compression Ratio	16.5:1
Compression pressure	> 12 bar
Maximum RPM	5250
Maximum continuous RPM	4400



Classroom Exercise - Facts and Figures

Discuss the topics listed amongst yourselves. Circle True or False next to the statements below. Your instructor will assist you in your discussions.

- | | | | |
|-----|---|------|-------|
| 1. | Diesel fuel costs less to refine from crude oil than gasoline | True | False |
| 2. | Gasoline is more heavily taxed than diesel fuel | True | False |
| 3. | Diesel fuel has more carbon content per gallon than gasoline | True | False |
| 4. | Glow plugs on BMW diesel engines are only used for cold starting | True | False |
| 5. | Diesel fuel is more volatile than gasoline | True | False |
| 6. | Hybrids are more efficient than diesels in all driving situations (e.g. Highway/City) | True | False |
| 7. | BMW allows the use of bio-diesel fuel (such as B10, B20 etc.) | True | False |
| 8. | Adding gasoline to a diesel fuel tank is acceptable in small amounts | True | False |
| 9. | Diesel engines operate best at Lambda values of 1.0 | True | False |
| 10. | Sulfur provides the necessary lubrication qualities found in diesel fuel | True | False |
| 11. | Diesels produce more untreated NO _x than gasoline engines | True | False |
| 12. | The new generation of BMW diesel vehicles will be sold in all 50 states | True | False |

Diesel Fundamental Principles

First and foremost, a diesel engine operates on the “compression ignition” principle. A compression ignition engine begins the combustion cycle without the need for an external ignition system.

What makes a diesel engine attractive to potential customers is that it is much more efficient than a gasoline engine. This is due to several factors:

- Diesel engines run at a much higher compression ratio
- The energy density of diesel fuel is much higher than an equivalent amount of gasoline
- Overall, diesel engines are more thermally efficient than gasoline engines
- Diesel engines are run very lean (with excess air)
- Diesel engines operate with the throttle in the open position which reduces pumping losses

In order to ignite fuel without a spark, the compression ratio must be relatively high. The compression ratio on most gasoline engines ranges from 8:1 up to as high as 12:1. On the other hand, compression ratios on diesel engines range from 16:1 up to about 22:1 for most passenger car engines.

A direct benefit of a higher compression ratio is increased thermal efficiency. In comparison to a gasoline engine of comparable displacement, modern diesel engines generate more cylinder pressure during the compression phase. The average “mean cylinder pressure” value of a turbocharged diesel engine is from 8 to 22 bar, while a comparable turbocharged gasoline engine is only about 11 to 15 bar.

A higher mean pressure value in combination with the higher energy density of diesel fuel translates to more pressure during combustion. This higher combustion pressure is responsible for much higher output torque. This additional torque is available at a relatively low RPM as compared to a gasoline engine.

The load control of a diesel engine is not carried out by regulating the amount of air as on a gasoline engine. Rather, the diesel engine is “throttled” by the amount of fuel injected. This type of load control means that the throttle butterfly is mostly open during all engine phases.

Since the throttle is always open, there is always more than enough oxygen available to burn all of the fuel injected. This allows the engine to operate in a very lean state which also contributes to increased efficiency of the diesel engine.

In comparison, gasoline engines must run at a lambda value as close to 1 as possible. A diesel engine can operate at lambda level of 1 to 2 under load and up to 10 when at idle or under low load conditions.

An added benefit of having the throttle open during most phases of engine operation is the reduction of pumping losses. This has the same beneficial effect that Valvetronic has on a gasoline engine.

In summary, early diesel engine designs were already much more efficient than the prevailing gasoline engine technology. However, fairly recent developments in engine and fuel injection technology have contributed to major advances in the success of the diesel engine.

In particular, modern BMW “Performance Diesel” engines provide the added bonus of economy **and** performance. The already proven diesel engine has been enhanced and optimized to fulfill the brand promise of “The Ultimate Driving Machine”.

Diesel Engine to Gasoline Engine Comparison

In order for the diesel engine to start its combustion cycle, fuel must be ignited by the heat of compression. The fuel used must be able to spontaneously ignite (without the help of a spark from an external ignition source). So, the fuel required for a diesel engine must have special properties to be compatible with proper engine operation. The best way to illustrate this is to compare both engines and the fuel used.

The following is a comparison of a gasoline engine as compared to a diesel engine:

Specification	Gasoline Engine (Otto)	Diesel Engine
Ignition Type	Spark Ignition	Compression Ignition
Compression Ratio	Between 8:1 and 12:1	Between 16:1 and 22:1
Efficiency	25-30%	36-45%
Maximum Engine Speed	7000-8250 RPM	up to 5250 RPM
Exhaust Temperature (under full load)	700-1200 Degrees Celsius	300-900 Degree Celsius
Fuel Type	Gasoline (Octane rating = resistance to knock)	Diesel (Cetane rating = ability to ignite)
Fuel Density	0.74 - 0.77	0.82 - 0.85
Flash Point	-47 Degrees Celsius (-52.6 Degrees Fahrenheit)	55 Degrees Celsius (131 Degrees Fahrenheit)
Ignition Temperature	550 Degrees Celsius (1022 Degrees Fahrenheit)	350 Degrees Celsius (662 Degrees Fahrenheit)

Combustion Cycle Comparison

Much like a gasoline engine, the diesel engine uses the 4-stroke cycle. The familiar sequence of; Intake > Compression > Power and Exhaust is much the same on a diesel engine. The difference is mostly in how the fuel is ignited and when fuel is introduced into the combustion chamber.

The other area in which diesel engines differ is in the compression ratio. The typical gasoline engine has compression ratios of between 8:1 up to about 12:1. On the other hand, diesel engines have a typical compression ratio of between 16:1 and 22:1. The higher compression ratio is required to sufficiently compress the air charge and raise the temperature to the ignition point.

The illustrations below show the sequence of the combustion cycle on a conventional **gasoline** engine with “manifold injection”.

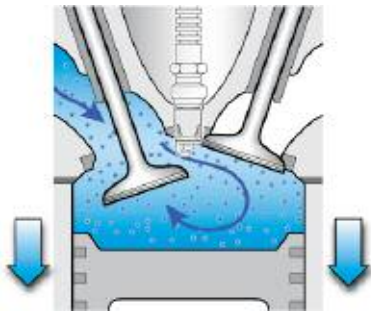

Intake Stroke Gasoline Engine

A low pressure area is created as the piston moves downward in the cylinder bore.

As the intake valve opens, a mixture of air and fuel is allowed to enter the cylinder to fill the void created by the low pressure area.

Note:

A gasoline direct injection engine would only induct air during this period.

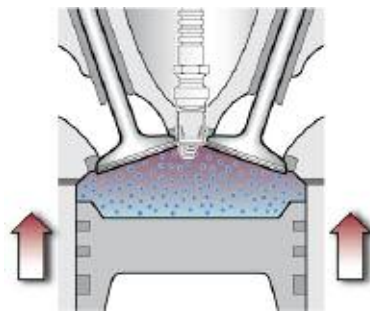

Compression Stroke Gasoline Engine

As the piston moves up in the cylinder, both valves are closed.

The mixture of air and fuel is compressed to a specific ratio.

Note:

A gasoline direct injection engine would only compress air during this period.

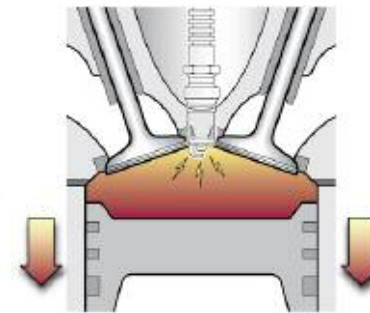

Power Stroke Gasoline Engine

The compressed air and fuel mixture is ignited by a spark from the ignition system.

The piston is forced down in the cylinder by the expanding gases. This creates the necessary force to drive the crankshaft.

Note:

A gasoline direct injection engine would inject fuel and ignite it with a spark during this period.

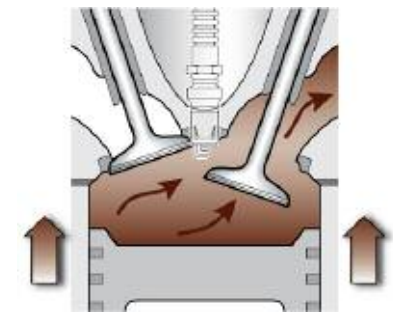

Exhaust Stroke Gasoline Engine

The exhaust valve opens as the piston moves up in the cylinder which expels the spent gases formed during the combustion process.

Note:

A gasoline direct injection engine would operate the same during this period.

Diesel Combustion Cycle

In the example above, the combustion cycle on the gasoline engine was discussed. In contrast, the sequence below outlines the combustion cycle on the diesel engine. This will help in the understanding of the diesel/gasoline engine comparison.

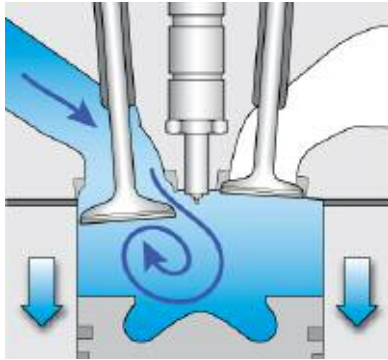

Intake Stroke Diesel Engine

A low pressure area is created as the piston moves downward in the cylinder bore.

As the intake valve opens, air is allowed to enter the cylinder to fill the void created by the low pressure area.

Note:

The recess in the piston and the design of the intake manifold assist in creating a “swirl effect” for the incoming air.

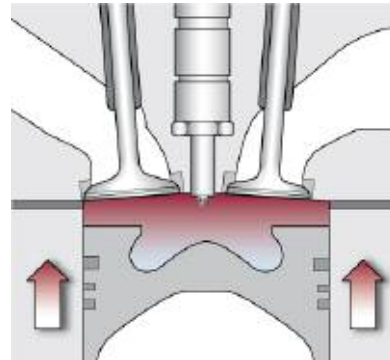

Compression Stroke Diesel Engine

As the piston moves up in the cylinder, both valves are closed.

The air is compressed to a high ratio and therefore heated to a high temperature in preparation for the incoming fuel.

Note:

Only air is compressed during this period.

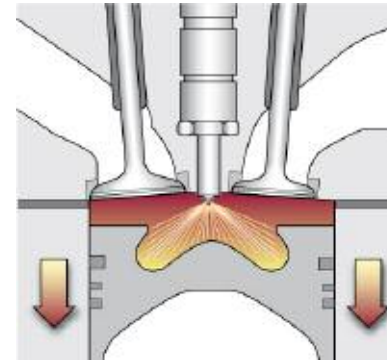

Power Stroke Diesel Engine

Just before the piston reaches TDC, fuel is injected at high pressure directly into the combustion chamber.

The fuel spontaneously ignites and pushes the piston down in the cylinder.

This creates the necessary force to drive the crankshaft.

Note:

Fuel is injected for a longer time during this period. This feature contributes to the additional torque generated by a diesel engine.

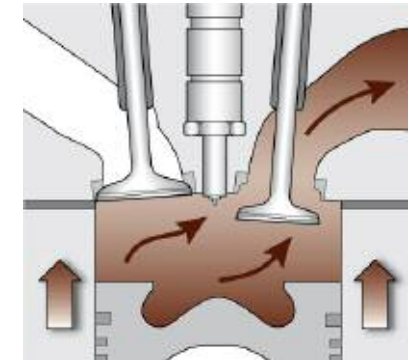

Exhaust Stroke Diesel Engine

The exhaust valve opens as the piston moves up in the cylinder which expels the spent gases formed during the combustion process.

Note:

Due to the higher thermal efficiency of a diesel engine, the exhaust temperature is lower as compared to a gasoline engine.

Diesel Fuel Properties

Before discussing diesel fuel injection or fuel systems, it is necessary to explain the properties of diesel fuel and how it differs from gasoline. Although both fuels are distilled from crude oil, they each have their own uses and applications and should never be interchanged.

Gasoline

The BTU value for gasoline is approximately 125,000 BTU per gallon

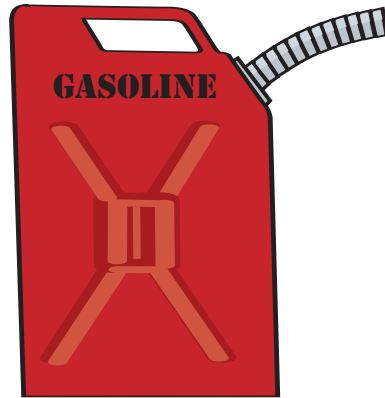

Diesel Fuel

The BTU value for diesel fuel is approximately 147,000 BTU per gallon

Diesel Fuel

As with gasoline, diesel fuel is a by-product of the distillation of crude oil. Diesel fuel is a hydrocarbon with different chemical properties than gasoline. Diesel fuel is part of the “middle distillates” derived from crude oil. This means that diesel fuel is “heavier” than gasoline but “lighter” than oil used for lubrication (i.e. motor oil). There are numerous advantages to diesel engines, due to the properties of the fuel used. Some of these advantages include:

- **Thermal Efficiency** - Diesel fuel produces more power than gasoline. In other words, Diesel fuel has a higher energy content. One gallon of gasoline contains about 125,000 BTU of heat energy. In comparison, one gallon of diesel fuel contains about 147,000 BTU. This advantage in thermal efficiency, adds up to increased fuel economy.
- **Increased Durability** - Due to the lubricant properties of diesel fuel, piston ring life is greatly increased. Gasoline has more of a detergent quality which tends to decrease piston ring life. It is not uncommon for light duty diesel passenger vehicles to have an engine which lasts more than 200,000 miles.
- **Improved Emissions** - Diesel fuel contains more carbon atoms per gallon and therefore will emit more CO₂ per gallon. However, the increased efficiency of a diesel engine allows for an overall reduction in CO₂ (per mile). In comparison, diesel engines are run leaner (with excess air), and produce lower levels of HC, CO and CO₂. The lower volatility of diesel fuel, allows for less evaporative emissions overall. The only area where diesel engines do not excel are in NO_x and Particulate Matter (PM). But, new technology allows diesel engines to comply with prevailing emission standards.

Diesel Fuel Types

The term “diesel fuel” is a generic term, it refers to any fuel for a compression ignition engine. As mentioned before diesel fuel is derived from the “middle distillates” of crude oil. There are other similar products in this range such as kerosene, jet fuel and home heating oil just to name a few. However, each of these products is designed for a specific application. In theory, these additional products may work in a diesel application, but it is not recommended. Diesel fuel has specific properties which are designed to offer the best reliability, the best fuel economy and the highest compatibility with engine and fuel system components.

As far as passenger cars are concerned, there are two main types of diesel fuel. These are Grade 1 and Grade 2. Usually referred to as Diesel Fuel #1 and Diesel Fuel #2. Mostly, Grade 2 is used for passenger cars and is the most widely available.

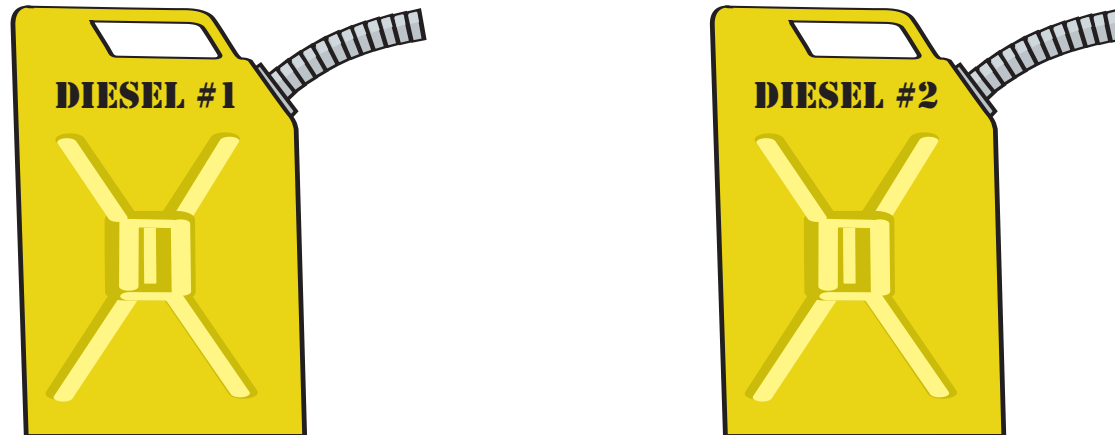

The difference between diesel fuel #1 and #2 is addressed in the following:

- Diesel #1 has about 95% of the BTU content as #2 diesel.
- Diesel #1 has a lower viscosity and provides less lubrication to the fuel system components such as the fuel pump and injectors.
- Diesel #1 has a lower waxing point than #2 and will perform better at low ambient temperatures.
- Diesel #1 usually has a slightly lower Cetane rating than #2, but is above the minimum rating of 40.

Winter Fuel

Petroleum companies generally offer “winter” and “summer” grade fuels on a seasonal basis. Winter fuel is created by blending a specific amount of #1 Diesel fuel to a quantity of #2 Diesel fuel. This lowers the freezing (waxing) point to prevent fuel filters from clogging or the fuel from causing any cold weather starting problems.

In the heavy trucking industry, there have been some other methods to “winterize” diesel fuel. Some of these methods include adding kerosene or other fuels to improve cold weather starting ability. However, this is **not** recommended for passenger cars and may, in fact, cause engine or fuel system damage. Therefore, the only recommended method is to purchase diesel fuel from a reputable retailer

Cetane Rating

When rating gasoline, the term “octane” has been used to refer to the anti-knock quality of a fuel. Octane rating refers to the resistance to prematurely ignite under pressure. When the octane number is higher, the fuel is more resistant to pre-ignition and therefore engine knock. Therefore, a higher octane number is more desirable. For example, today’s octane ratings range from 87 to 93 for commercially available passenger cars.

In Diesel applications, the term “cetane” is used to rate fuel quality. However, the desired fuel quality goals are different for diesel. The cetane rating of diesel fuel refers rather to the “ease of ignition”. After all, a diesel engine is a “compression ignition” engine and therefore, it is more important for diesel fuel to combust easily under pressure. Cetane ratings are in a range of 0 to 100. 100 is an indicator of pure Cetane (n-hexadecane), or the most combustible. Most commercially available diesel fuel has a cetane rating of about 45. A rating of 40 is usually considered to be the absolute minimum rating for today’s passenger vehicles. Newer BMW vehicles will require a Cetane rating of 51. Always check the owner’s manual to see the minimum fuel requirements and the recommended cetane number. A higher cetane rating also contributes to better starting especially in cold weather. When possible, it is always better to use fuel with a higher cetane rating. Also, a higher cetane number equates to a reduction in NO_x and particulate matter emissions.

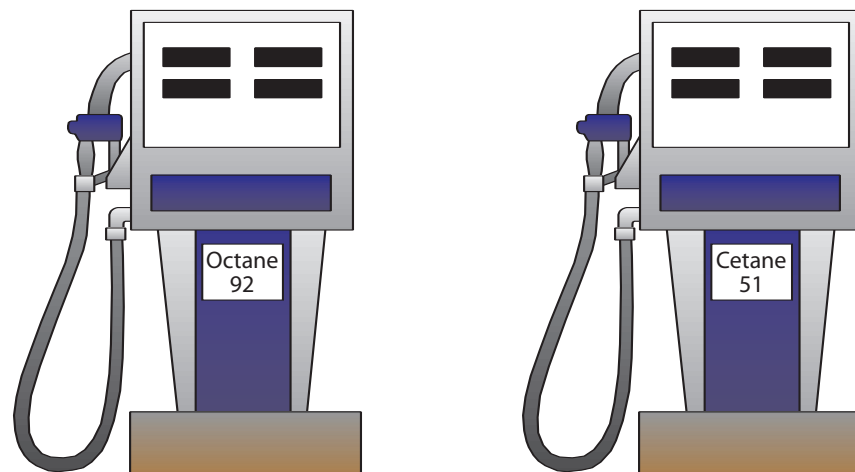

Cold Weather Properties

As with all fuels distilled from crude oil, there is a presence of paraffin wax. This wax content depends of the type of fuel. Since diesel fuel is a “middle distillate” of crude oil, there are more paraffin compounds present. These waxy compounds flow well at normal ambient temperatures. However, in cold operating temperatures, these compounds begin to solidify and can restrict fuel flow resulting in difficult starting.

■ Cloud Point

The cloud point is the temperature at which the fuel will start to solidify. The paraffin compounds begin to crystallize and the fuel becomes cloudy. The ability of the fuel to flow is impeded, but is still able to move through the system. The cloud point of #2 Diesel fuel is about 20 degrees Fahrenheit (-7 degrees C).

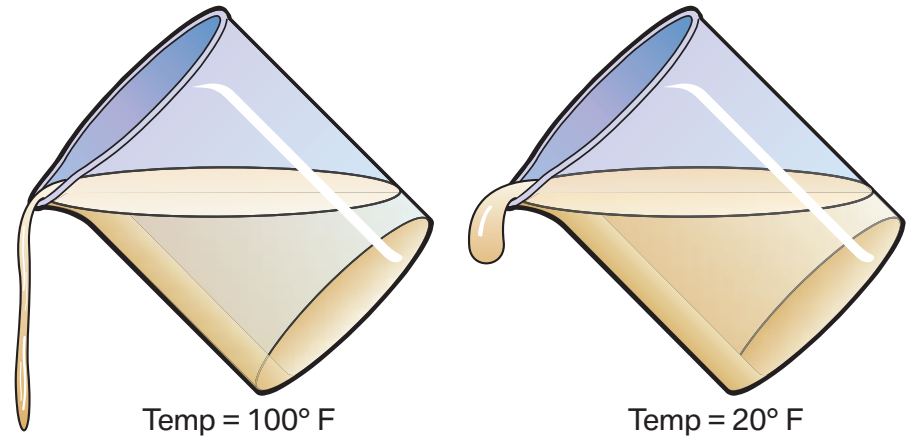

Pour Point

Pour point is the temperature in which the fuel will no longer flow. It is usually 6 to 10 degrees Fahrenheit below the cloud point.

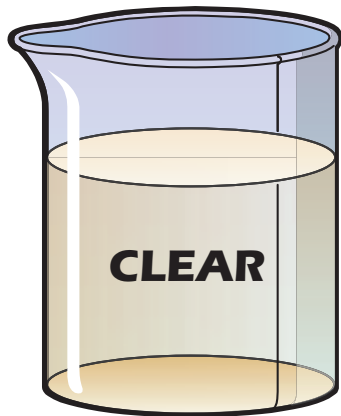

Temp = 100° F

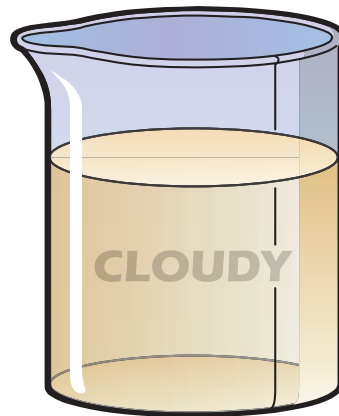

Temp = 30° F

■ Cold Filter Plugging Point (CFPP)

Diesel fuel is a hydrocarbon which contains paraffin waxes. At warm temperatures, these waxes will flow easily through the fuel system. However, at low ambient temperatures, these waxes will tend to solidify. This situation causes the fuel to start to solidify. Due to the paraffin content in middle distillate's like diesel fuel, it is possible during cold temperatures for the fuel to solidify. The CFPP is about -4 degrees F (-20 degrees C).

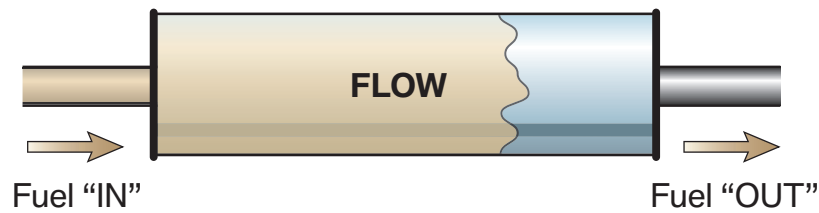

■ Cold Climate Measures

Most, if not all, modern vehicles equipped with diesel engines employ measures to heat the fuel and reduce the possibility of wax formation a.k.a gel. The measures include a heated fuel filter and glow plugs. These systems will be discussed in subsequent training modules.

■ Diesel Fuel Additives

When diesel fuel is refined, numerous additives are used to improve the qualities of the fuel. These additives can be introduced at the refinery level or at the distribution level. One such additive is an "Anti-foaming" agent which helps when refueling the vehicle by reducing the foam buildup when the fuel is aerated.

Detergents are added to allow the diesel fuel to assist in the cleaning of engine and fuel system components. These detergent combat the possibility of sediment or "gum" buildup which can be detrimental to the fuel system. Modern high pressure diesel fuel injection systems are sensitive to any dirt or varnish buildup.

California requires the use of low aromatic diesel fuel. Additives are used in this case to lower the aromatic quality of the fuel. In the future, some other states may require the use of "low aromatic" diesel fuel.

Some additional additives include:

- Cetane number improvers
- Smoke suppressants
- Low temperature operability additives
- Biocides (to prevent growth of microbes in the fuel)
- Corrosion inhibitors
- Dyes (for identification)
- Lubricity additives

■ Dyes

Dyes are added to diesel fuel for identification. There are two primary reasons that fuel needs to be identified. The IRS requires diesel fuel to be identified for tax purposes and the EPA requires fuel to be identified for fuel quality (i.e sulfur content).

To comply with the tax code, fuel is usually dyed red for agricultural use. The fuel used for farm equipment is not as heavily taxed as that which is used for "over-the-road vehicles. Using "red-diesel" in a passenger car or truck is a violation of the tax code and therefore should not be used.

The so-called "red diesel" fuel is also dyed to show visible evidence of "high-sulfur" fuel.

Starting in 2007, the diesel fuel used in new cars is supposed to be “ULSD” or Ultra-low Sulfur Diesel. The EPA requires a specific quantity of red dye to be used in any fuel which is not of the ULSD variety.

The sulfur content of this fuel has been drastically reduced to help modern vehicles meet emission requirements. Therefore, “red diesel” should not be used in any “over-the-road” vehicle.

■ **Microbes**

When fuel is refined, the high temperatures achieved during this process will “sterilize” the fuel. However, after the fuel has cooled, it is possible for microorganisms to grow.

This is possible because there is usually some water present in diesel fuel which comes from condensation and during the transfer/distribution phases.

The microbes feed on the interface between the water and fuel. These colonies can thrive in the absence of light. Some microbes are also anaerobic, which means they can survive in the absence of oxygen as well.

These microbes can multiply into colonies which can become large enough to clog fuel system components. The best way to combat these organisms is to keep the fuel as clean as possible and reduce or eliminate the presence of water.

Diesel fuel distributors use biocides to attack the microbes and reduce their numbers.

Sulfur Content

Sulfur is a naturally occurring element found in crude oil. Through the refining process various sulfur compounds occur and are present in the final product. Up until 1985, not much attention was paid to the sulfur content in diesel fuel.

The presence of sulfur in diesel fuel contributes to unwanted soot and particulate emissions which are present in diesel exhaust. So, beginning in 1985, the EPA and CARB began with regulations on the sulfur content of diesel fuel. This led to the use of low sulfur diesel fuel.

Up until 2007, diesel fuel regulations required the use of “Low Sulfur Diesel” or LSD. The sulfur content of LSD is 500 parts per million. LSD fuel was compatible with the diesel technology at that time, but there was still substantial particulate matter emissions (PM).

For the 2007 model year, the EPA has mandated the use of Ultra Low Sulfur Diesel fuel or ULSD. This new fuel represents a 97% decrease in sulfur content. The maximum sulfur content in ULSD is 15 ppm. As a comparison, this amounts to about 1 ounce of sulfur for an entire tanker truck of diesel fuel.

One of the reasons that ULSD fuel is needed is to be compatible with the latest generation of “clean diesel” vehicles. These vehicles include a Diesel Particle Filter (DPF) which is used in the exhaust system to trap and reduce particulate emissions. The use of ULSD assists greatly in the reduction of particulate matter emission.

Using LSD fuel in a vehicle which requires ULSD can damage the DPF and result in unwanted emission levels and unnecessary component damage. So, only ULSD fuel should be used especially on vehicles equipped with a DPF.

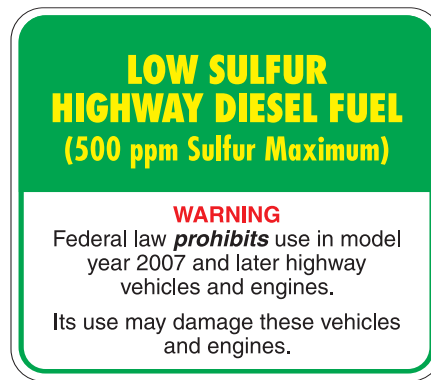
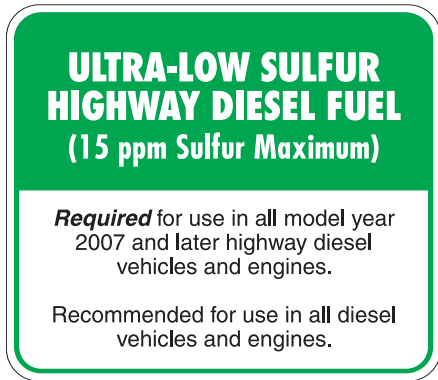

When refueling a vehicle which requires ULSD, be sure to check the label located on the pump. This label should be in a conspicuous location. Above, is an example of the correct label for ULSD fuel on the left. The right is an example of LSD fuel (pre-2007).

By December of 2010, all gas stations are required to be in compliance with the ULSD requirements. As of 12/10, LSD fuel will no longer be available for highway use.

Vehicles which require LSD will be able to run on ULSD without any modifications. The ULSD fuel meets all lubricity requirements for vehicles made prior to 2007.

■ Lubricity

One of the qualities of diesel fuel is that it provides the needed lubrication for engine and fuel system components. By nature, diesel fuel is very oily and is more viscous (thicker) than gasoline. This is why diesel fuel is sometimes referred to as fuel oil.

Some components such as the injectors and high pressure pump will not function properly without lubrication. The presence of sulfur and sulfur compounds contribute to the overall lubrication qualities of the fuel.

With LSD fuel and the new ULSD, additives are used to enhance the lubricity of the fuel. So, older vehicles will be able to ULSD without any modifications or concerns.

■ Grades

ULSD fuel will be available for both Diesel #1 and Diesel #2 grades.

■ Off Road Use

Currently, ULSD is not required for “off-highway” use. This includes agricultural equipment, locomotive and marine use. ULSD will not be required on these applications until 2010. Until that time, LSD fuel with 500 ppm sulfur will be available (see label below).

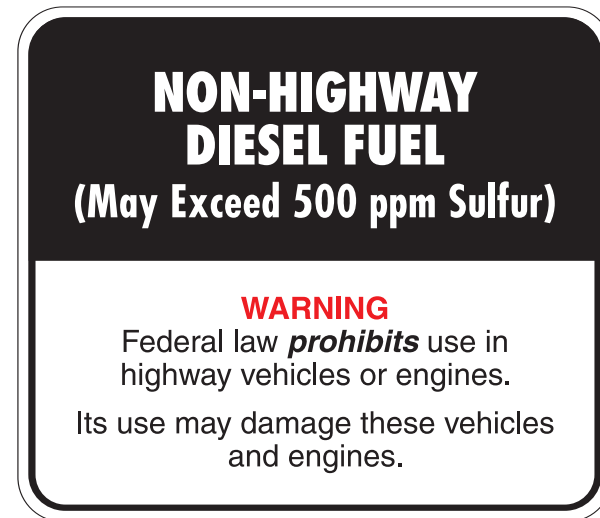

Flash Point and Auto-ignition

The flash point of a fuel represents the lowest temperature as to which it will be able to be ignited. Gasoline and diesel fuel have different properties, and therefore different flash points.

A gasoline engine or “spark ignition” engine needs a fuel which can be ignited by a spark, but will not “self-ignite” under the heat of compression. Gasoline which has a lower flash point than diesel fuel can be ignited easier with an outside source of ignition i.e. spark or open flame. The flash point of gasoline is at about -43 degrees Celsius (-45 F) which works well in a gasoline engine, but not in a diesel. A low flash point also makes gasoline more dangerous to handle.

Gasoline, however, has a higher auto-ignition temperature which helps the fuel resist self ignition in a gasoline engine. The auto-ignition temperature of gasoline is about 256 degrees C or 475 degrees Fahrenheit.

Diesel fuel has a much higher flash point of about 52 degrees C or above. This flash point varies between fuel types i.e. #1 or #2 diesel. In contrast, the auto-ignition temperature of diesel fuel is 210 degrees C or 410 degrees Fahrenheit. This particular quality of diesel fuel is compatible with a “compression ignition” engine.

■ Fuel Mixing

Among the other attributes of automotive fuels, flash point and auto-ignition temperature are perhaps the primary reasons why these fuels should never be mixed. Mixing gasoline into diesel fuel will lower the flash point rendering the fuel unsafe to handle. Also, the flash point and auto-ignition temperature of gasoline would adversely affect a diesel engine, even to the extent of engine damage.

With regards to a diesel engine, it is also important to be aware that gasoline has little in the way of lubrication properties sufficient for diesel fuel system components. This is of a particular concern to the high pressure fuel pump which can be damaged when gasoline is introduced into the fuel system.

The inverse is also true when fueling a gasoline powered vehicle incorrectly with diesel fuel. Irreparable engine damage can result costing thousands of dollars.



In Diesel Engines

Diesel Oil

In addition to the fuel used to run a diesel engine, there are also considerations which must be taken into account regarding the lubricating oil in a diesel engine. Since the combustion chamber temperature of a diesel engine is higher than a gasoline engine, the oil temperature is also higher. So, engine oils used in diesel engines must be able to withstand the higher temperature demand.

In addition to the already high service demand on diesel engine oil, BMW diesel engines are turbocharged which further increases the demands on the engine oil.

In the U.S., lubricating oils are rated through the American Petroleum Institute (API). Engines, whether gasoline or diesel powered, each have their own classification as far as lubricating oils are concerned.

The lubricating oil used in current diesel engines must conform with regulations regarding sulfur content.

For the correct motor oil for diesel engines, always refer to the proper owner's manual or the "Operating Fluids Specifications Manual" which can be found in BMW TIS.



NOTES

PAGE



Workshop Exercise - Diesel Engine Fundamentals

You will notice that your classroom is set up with various “Information Stations”. The following workshop exercises pertain to these stations. Proceed to the station which pertains to the topics listed below.

Information Station 1 (Mechanical):

Compare the two pistons, note the differences and answer the following questions.

1. As compared to the piston on the gasoline engine, the diesel piston is: (Circle all that apply)
Heavier Lighter Larger Smaller
2. In the following exercise, circle the **TRUE** statements regarding the pistons on a diesel engine: (Cross out false statements)
 - A. The first piston ring land on a diesel engine is relatively close to the piston crown
 - B. The piston skirt on a diesel engine is deeper than the skirt on a gasoline engine
 - C. On a diesel engine, the piston pin is tapered for weight savings
 - D. The piston pin has a bushing in the connecting rod, but not in the piston (TOP engine).
 - E. The diesel piston contains a major portion of the combustion chamber
 - F. The diesel piston is made from cast iron to withstand high temperatures

Compare the two connecting rods, note the differences and answer the following questions.

3. Circle the **TRUE** statements regarding the connecting rods on a diesel engine:
 - A. The diesel connecting rod has a bushing in the “small end”
 - B. The “small end” of the diesel connecting rod is tapered for weight reduction
 - C. The big end of the connecting rod uses dowel pins for alignment
 - D. The diesel connecting rod is made from forged steel
 - E. The diesel connecting rod is lighter than a connecting rod on a gasoline engine



Workshop Exercise - Diesel Engine Fundamentals

Examine the connecting rod bearings and answer the following questions:

4. Circle the **TRUE** statements regarding connecting rod bearings on a diesel engine:
 - A. The sputter bearing is comprised of 3 layers
 - B. The sputter bearing should be installed in the connecting rod bearing cap
 - C. The sputter bearing has a soft layer to absorb dirt particles
 - D. The sputter bearing is marked with an “S” on the back of the bearing shell

Examine the crankcase information and answer the following question:

5. Circle the **TRUE** statements regarding crankcase on a diesel engine:
 - A. The diesel crankcase has an “open deck” design
 - B. The diesel crankcase uses a “bedplate” for added rigidity in the bottom end
 - C. The diesel crankcase is made from aluminum and has cast iron cylinder liners
 - D. The main bearing caps on a diesel engine are located using dowel pins for precise alignment

Examine the cylinder head and valvetrain components and answer the following question:

6. Circle the **TRUE** statements regarding cylinder head and valvetrain components on a diesel engine:
 - A. The intake and exhaust valves on a diesel engine are all the same diameter
 - B. The major portion of the combustion chamber is located in the cylinder head
 - C. The exhaust valves are sodium filled on a diesel engine
 - D. The camshafts are manufactured from cast iron on a diesel engine
 - E. The exhaust camshaft is driven via a gear-to-gear connection with the intake camshaft



Workshop Exercise - Diesel Engine Fundamentals

Information Station 2 (Fuel System):

Examine the fuel system components and use the poster to determine fuel system operation.

Answer the following questions:

1. Which of the following methods is used to drive the high pressure pump on the M57TU2 TOP?
(Circle the correct answer)
 - A. Via a direct connection to the exhaust camshaft
 - B. Via a sprocket connection to the timing chain
 - C. Via a lobe on the intake camshaft
 - D. Via a tandem to the vacuum pump
2. Which of the following statements is **NOT** true regarding the low pressure fuel system on the diesel engine (M57)?
(Circle the correct answer)
 - A. The fuel filter is heated to assist in cold starting
 - B. The EKP module controls the fuel pump based **only** on load-based “demand” information from the DDE
 - C. The low pressure fuel pump is located in the fuel tank
 - D. The EKP module is connected to the PT-CAN
3. Which of the following statements is **NOT** true regarding the common rail system?
(Circle the correct answer)
 - A. The high pressure pump is a 3-piston radial type pump
 - B. The fuel injectors are “piezo-electric”.
 - C. The injectors are identical in operation to those on the N54 (gasoline) engine
 - D. The high pressure fuel pump is lubricated by pressurized engine oil
 - E. Fuel pressure on the common rail system is 200 bar



Workshop Exercise - Diesel Engine Fundamentals

Information Station 2 (Fuel System):

4. Review the statements (A-L) below and circle all of the **TRUE** statements regarding the the properties of diesel fuel?
(Circle the correct answer)
- A. Diesel fuel has more “carbon content” than gasoline
 - B. Diesel fuel #1 is more commonly used in moderate climates
 - C. The Cetane rating of diesel fuel refers to the ease of ignition
 - D. Diesel fuel and gasoline can be mixed in small amounts without any concerns
 - E. Diesel fuel is more volatile than gasoline
 - F. Diesel fuel contains more sulfur than gasoline
 - G. ULSD diesel fuel contains less than 15 ppm of sulfur
 - H. Diesel fuel (when combusted) will emit more CO₂ per mile than gasoline
 - I. Bio-diesel fuel is currently not approved for use in BMW diesel vehicles
 - J. BMW diesel engines will only run of diesel fuel which has a Cetane rating of 80 or higher
 - K. Diesel fuel evaporates at a higher rate than gasoline
 - L. Diesel fuel is less expensive to refine than gasoline



Workshop Exercise - Diesel Engine Fundamentals

Information Station 3 (Combustion Process):

Using the diesel demonstrator, place a small piece of cotton in the tube and press down rapidly on plunger. Take note to see if any combustion takes place.

1. Did combustion take place? (why or why not?)

Try spreading the cotton apart and re-try.

2. Did combustion takes place this time?

3. Based on your results, how does the presence (or lack of) oxygen affect combustion?

4. How does the shape and size of the cotton affect combustion? How does this relate to actual combustion in a diesel engine?

5. Which of the following statements are **NOT** true regarding the diesel combustion process?

- A. The fuel mixture on a diesel engine is formed externally
- B. Diesel engines operate most efficiently at a Lambda value of less than 1
- C. The fuel mixture on diesel engines is considered to be “homogeneous”
- D. Fuel is injected into a diesel engine just before the end of the compression stroke



Workshop Exercise - Diesel Engine Fundamentals

Information Station 4 (Air Management):

1. Which of the following statement is **NOT** true regarding the throttle valve on a diesel engine?
 - A. BMW diesel engines do not have a throttle valve
 - B. The throttle on BMW diesel engines is used to control engine load
 - C. The throttle is used to control shudder on engine shut down
 - D. The throttle is used to prevent engine over-rev from excessive oil consumption

2. The swirl flaps on the M57 engine are closed: (Circle the correct answer)
 - A. All of the time
 - B. Only at low RPM/load conditions
 - C. Only at high RPM/load conditions
 - D. Only during engine shutdown
 - E. to reduce engine noise

3. The swirl flaps are located:
 - A. In the exhaust system
 - B. In the intake manifold
 - C. In the air filter housing
 - D. In the cylinder head
 - E. In the throttle housing



Workshop Exercise - Diesel Engine Fundamentals

Information Station 5 (Auxiliary Systems):

1. Circle all **TRUE** statements regarding glow plugs: (Circle all that apply)
 - A. Glowplugs provide heat in the combustion chamber at low ambient temperatures
 - B. Glow plugs are not activated during engine operation (engine running)
 - C. Glow plugs reduce engine noise
 - D. Glow plugs contribute to a reduction in exhaust emissions
 - E. Glow plugs must be changed every 20,000 miles
 - F. Modern BMW glow plug circuits are wired in series
 - G. Glow plug circuits are individually diagnoseable

2. Fast start glowplugs: (Circle all correct statements)
 - A. Operate on a PWM control circuit
 - B. Operate on a high voltage (12 volts)
 - C. Operate on a low voltage (5.3 to 7.8 volts)
 - D. Have low internal resistance
 - E. Have high internal resistance

3. The vacuum controlled motor mounts are actuated (supplied with vacuum): (Circle all correct statements)
 - A. Above 900 RPM
 - B. Below 60 km/h
 - C. At idle
 - D. All the time



Workshop Exercise - Diesel Engine Fundamentals

Information Station 6 (Emission Controls):

1. The DPF controls the output of:
 - A. HC
 - B. CO
 - C. PM (soot)
 - D. NO_x
 - E. CO₂
2. Which of the following exhaust gas constituents is of most concern on a diesel engine?
 - A. HC
 - B. CO
 - C. PM
 - D. NO_x
3. Which of the following sensors is NOT used on a diesel engine management system?
 - A. Exhaust gas temperature sensor
 - B. Exhaust gas pressure sensor
 - C. Post-catalyst oxygen sensor
 - D. Air charge temperature sensor



Workshop Exercise - Diesel Engine Fundamentals

Information Station 6 (Emission Controls):

4. Which two components are installed in the same housing on current BMW diesel vehicles?
 - A. DOC and DPF
 - B. SCR and DOC
 - C. DPF and SCR
 - D. EGR and DOC
 - E. DPF and EGR

5. The SCR system uses a urea compound which breaks down into _____ when entering the SCR catalyst?
 - A. NH_3
 - B. NO
 - C. O_2
 - D. CO_2
 - E. N_2

6. Which of the following components is used to monitor EGR performance (flow)?
 - A. Exhaust gas temperature sensor
 - B. Exhaust gas temperature sensor
 - C. Air charge temperature sensor
 - D. Hot-film air mass meter
 - E. Air charge pressure sensor



Workshop Exercise - Diesel Engine Fundamentals

Information Station 6 (Emission Controls):

7. Which of the following will occur in order to initiate DPF regeneration?
 - A. Pre-injection events
 - B. Post injection events
 - C. The throttle is held wide-open
 - D. The swirl flaps are closed

8. Swirl flaps are used to lower NO_x :
 - A. At high RPM
 - B. At low RPM
 - C. On deceleration
 - D. Swirl flaps do not influence NO_x

9. At idle, diesel engine operate at a Lambda value of:
 - A. .85
 - B. 1.0
 - C. 1.15
 - D. Over 2.0

Engine Mechanical

In the early stages of diesel engine development, most if not all were used in stationary applications for power generation, pumping or to provide motive power for large ships. The engines were heavy and impractical for use in ground transportation. During the early part of the 20th century, diesels were gradually downsized and improved to make mobile applications possible.

Although diesel engines were always more mechanically and thermally efficient than gasoline engines, the early designs were heavy and took up a lot of space. So, much of the early development of “mobile” diesel engines centered around heavy trucks.

By the time diesel engines were adapted to automobiles in the 1930’s, the engine size was reduced and lightened considerably. But, this weight reduction was still not enough to make the diesel engine a great performer.

Most of the early automotive diesel engines were using cast iron cylinder blocks and cylinder heads. The fuel efficiency that was gained from the use of diesel engines was somewhat offset by the heavier engine designs. As a result, performance suffered and the overall opinion of diesel engines was that they were slow and sluggish.

BMW did not start to develop a diesel engine until the late 1970’s when fuel prices were on the incline and the environment was becoming a concern. The sluggish performance of early diesel engines did not fit into the “sporty” driving style of BMW customers. Over the years, other vehicle manufacturers designed diesel engines and marketed diesel powered vehicles, but most were not considered sporty or high-performance in any way.

Therefore, BMW needed to develop a diesel engine that was a “real” alternative to the gasoline engine. Anything less would not fit into the image of the “Ultimate Driving Machine”.



The development of the M21 engine was preceded by an experimental diesel engine known internally as the M105 which was initially developed in 1978. The production version of the first BMW diesel engine (M21) would be introduced in 1983.

Early BMW diesel engines utilized cast iron for crankcase construction. This was due to the high combustion chamber pressures generated in the diesel combustion cycle.

The latest diesel engines from BMW take advantage of advancements in aluminum casting technology. This allows the current and future diesel engines to be lighter without compromising strength. Some of the other areas which are different in diesel engines extend to many of the internal engine components.

These areas include pistons, crankshaft, connecting rods, cylinder head and valvetrain. These components are generally stronger and are constructed of different materials as compared to their counterparts on gasoline engines.

Engine Construction Comparison

In order to be compatible with the higher combustion pressures and torque output in a diesel engine, the crankcase must be stronger and more robust than a gasoline engine. Early BMW diesel engines used a cast iron crankcase, but current advances in aluminum casting technology have allowed the use of lightweight alloy cylinder blocks for diesel applications. The new M57 aluminum crankcase saves 20 kg over the cast iron version.

One of the first engines to use this technology was the M57TU2 (6-cylinder) and later the M67TU (8-cylinder). Both of these engines were introduced for the 2005 model year (in non-US markets). The aluminum crankcase has externally cast ribs in addition to stronger aluminum alloy to ensure optimum block rigidity.

The graphics shown below are an illustration of the differences between the crankcase on a diesel engine as compared to a crankcase used on a gasoline engine. Note the additional cast ribs on the diesel crankcase which contributes to the needed rigidity. Block rigidity is further optimized by the closed deck design as compared to the open deck on the N54/N52 engine.



Crankcase for diesel engine (M57TU2 aluminum)



Crankcase for gasoline engine (N54 aluminum)

Pistons, Crankshaft and Connecting Rods

One of the major differences between gasoline and diesel engines is in the pistons. The pistons on a diesel engine are subjected to very high pressures and therefore must be considerably stronger. On the diesel piston, a portion of the combustion chamber is in the crown.

Piston, diesel engine - typical



■ Piston - Diesel Engine

As can be seen from the above graphic, the diesel piston is more robust. The piston crown and skirt are noticeably thicker. As far as material is concerned, a stronger aluminum alloy is used. The area between the piston crown and the first ring land (fire land) is much larger than that used on a gasoline engine.

The piston crown itself is unique and features minimal valve reliefs and a large recess. This recess is used to accommodate the injector spray pattern and assist in mixture formation. The piston pin is also larger and features a bushing in the piston pin boss.

An oil cooling passage in the piston allows for a jet of pressurized oil to completely encompass the underside of the piston to keep it piston crown cool. This increases piston and ring life while helping to lower NO_x.

Piston, gasoline engine - typical

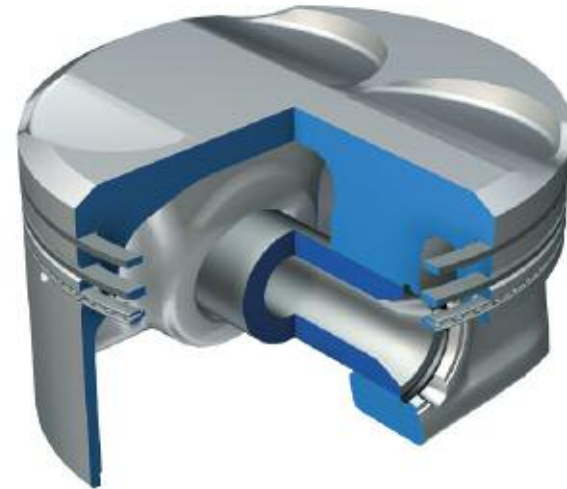

■ Piston - Gasoline Engine

This gasoline piston above reflects the type used on a conventional gasoline engine. The piston skirt as compared to the diesel piston is quite thin. The design goals on a gasoline piston include making a strong but lightweight unit which is also "friction optimized".

The valve reliefs are more pronounced to accommodate additional valve lift. The piston pin is smaller and tapered to save weight without compromising strength.

In order to contain the additional forces generated in the diesel combustion cycle, the crankshaft is made from forged steel, cast iron crankshafts are not used. In some cases, the crankshaft journal diameters are slightly larger as well. This is dependent upon the engine version.

The connecting rods must also be stronger to accommodate the additional forces from the combustion process. To accomplish this, the rods made from forged steel and are significantly thicker in the beam area and have a larger piston pin.



Cylinder Head and Valvetrain

The cylinder head on a diesel engine differs in several ways as compared to a cylinder head on a gasoline engine. Obviously there are no accommodations for spark plugs, but rather glow plugs are centrally located in the combustion chamber.

The fuel injector is also located centrally in the combustion chamber adjacent to the glow plug.

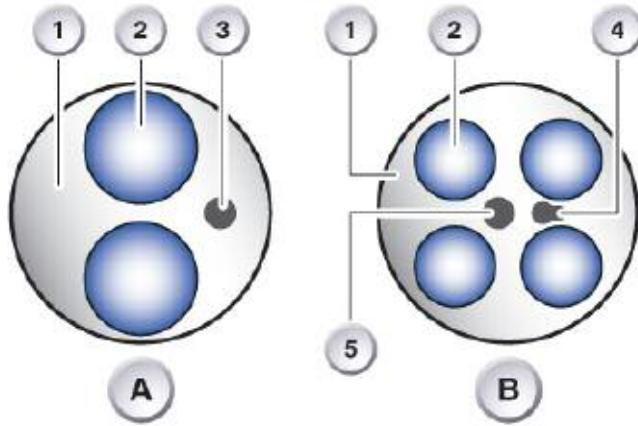

Index	Explanation
A	2-Valve arrangement (i.e. M21)
B	4-valve arrangement (i.e. M57)
1	Combustion chamber (surface/ceiling)
2	Valves
3	Injection port (swirl chamber/glow plug integrated)
4	Glow plug
5	Injector (direct injection)

The angle of the valves on a BMW diesel engine are also slightly different as compared to a gasoline engine. Gasoline engines depend upon the optimization of intake air flow to meet volumetric efficiency requirements. So, BMW gasoline engines depend upon the design of the intake and cylinder head to achieve these goals.

On the other hand, diesel engines are already efficient in this area due to the fact that the throttle is open most of the time. This reduces pumping losses and improves air flow without the use of special designs. When comparing the cross-sectional views of the two cylinder heads below, notice the angle of the valves. The gasoline engine utilizes a more extreme angle between the intake and exhaust valves to improve flow and help form the shape of the combustion chamber. The diesel engine has a valve layout that is much less extreme and the combustion chamber is relatively non-existent.

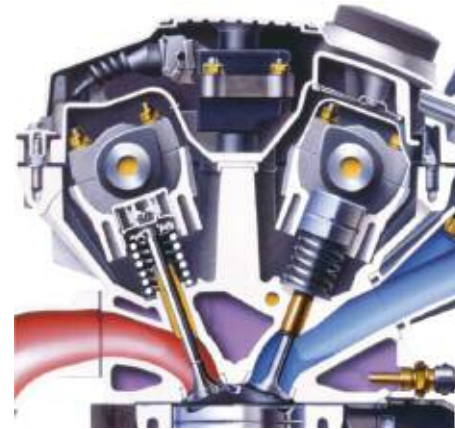

Cylinder head cross section
Gasoline Engine

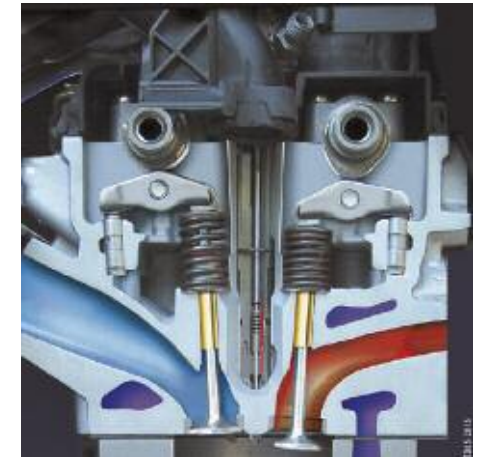

Cylinder head cross section
Diesel Engine

It is also important to note that the intake and exhaust valves on gasoline engines are of different sizes, with the intake valves being larger than the exhaust valves.

The N54 engine, for example, has intake valves which are 31.5 mm and exhaust valves of 28 mm diameter. Some of the earlier diesel engines have had valves which are the same size. The M57TU1 TOP, which is not a US version engine, has a valve diameter of 25.9 mm for all valves, both intake and exhaust. However, the M57TU2 TOP (M57D30T2) uses only a slightly larger intake valve of 27.4 millimeters.

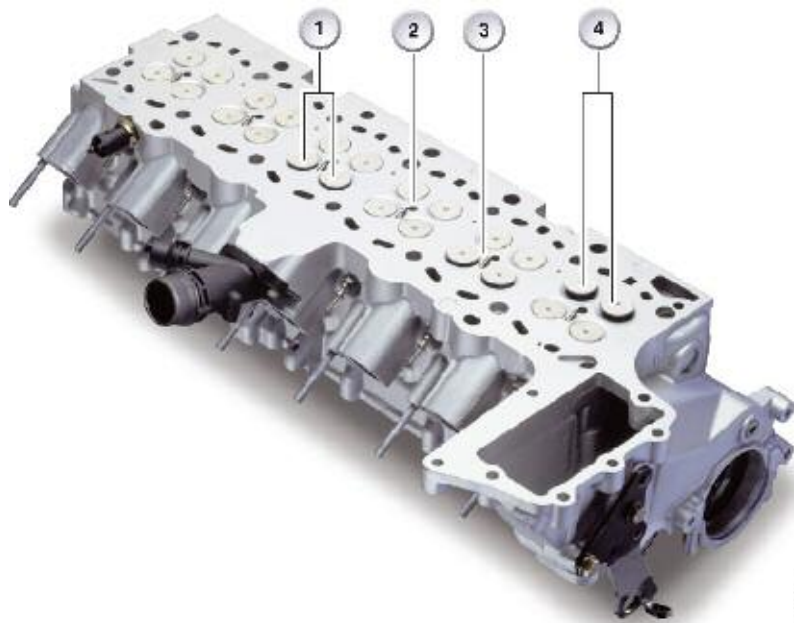

Index	Explanation
1	Intake valves (27.4 mm)
2	Injector (direct injection)
3	Glow plug
4	Exhaust valves (25.9 mm)

Camshafts

The camshafts on the M57 are a composite design for weight savings. This process is referred to as the “Presta” process which uses a steel tube for the camshaft. The tube is rolled to create a “knurled” area around it’s circumference.

The lobes have splines which interfere with the knurling on the camshaft tube. The lobes are pressed on and locked to the camshaft in the specified positions.

This process provides strength with a considerable reduction in weight.

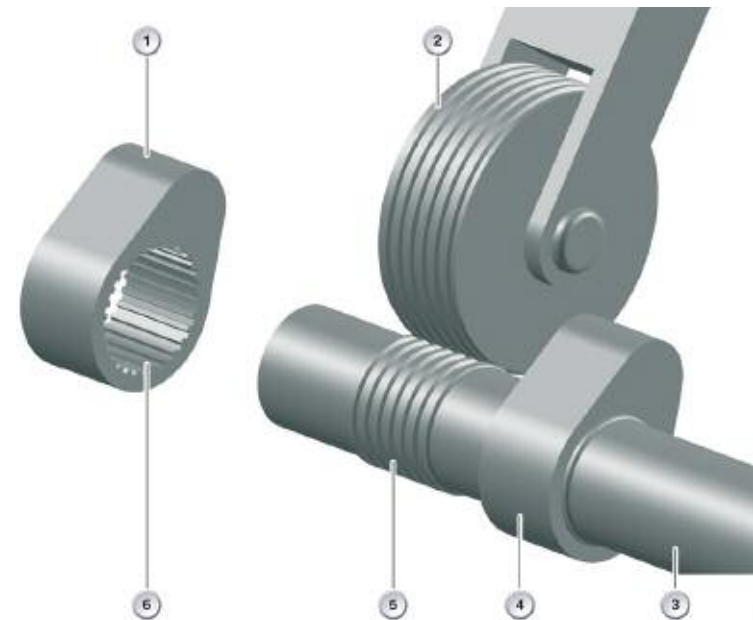

Index	Explanation
1	Camshaft lobe
2	Roller for Presta process
3	Camshaft (steel tube)
4	Camshaft lobe (locked on to steel tube)
5	“Knurling” on camshaft
6	Internal splines on camshaft lobe

Lubrication System

The oil circuit serves the purpose of supplying with oil all points in the engine requiring lubrication and cooling. As with all BMW engines, the diesel engine is equipped with a forced feed lubrication system. The oil drawn in by the oil pump from the oil pan via an intake pipe flows through the full-flow oil filter and then passes into the main oil gallery or channel which normally runs parallel to the crankshaft in the engine block.

Branch galleries lead to the main bearings of the crankshaft. The crankshaft has corresponding holes to feed oil from the main bearings to the crankpins and connecting rod journals. Part of the oil is branched off from the main oil gallery and fed to the corresponding lubrication points in the cylinder head. The following system overview uses the M57 engine as an example to demonstrate the general layout of the oil circuit.

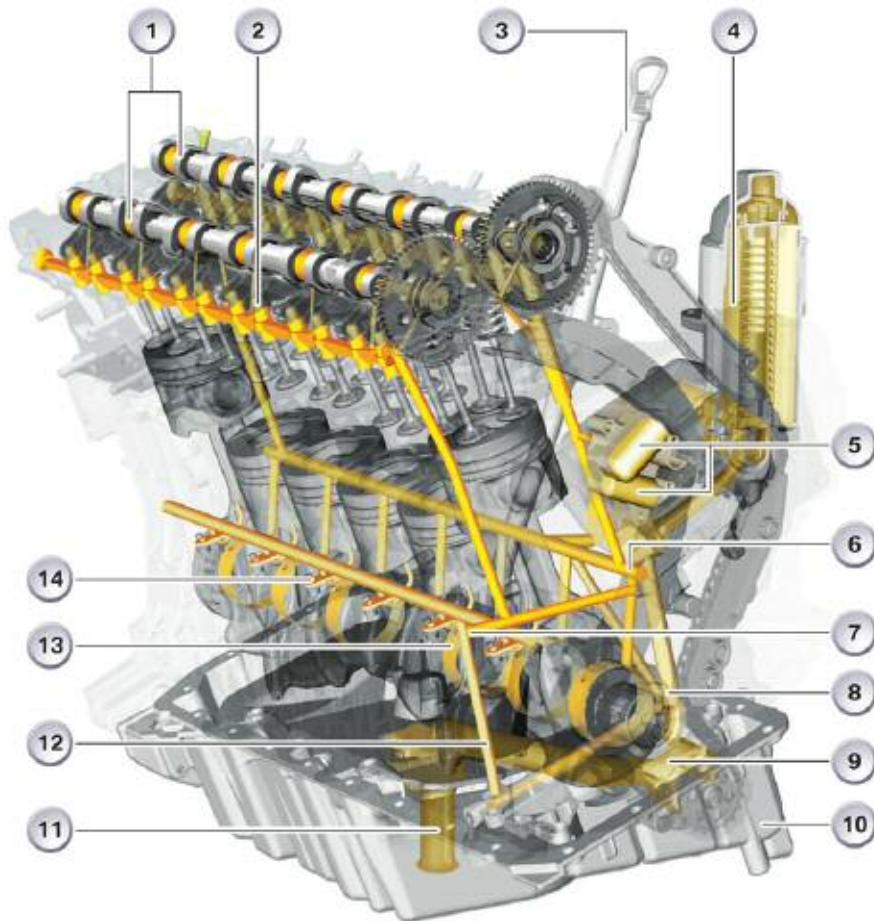

Index	Explanation
1	Camshaft bearing
2	HVA
3	Oil dipstick
4	Oil filter
5	Chain tensioner
6	Main oil gallery
7	Oil supply, exhaust turbocharger
8	Unfiltered oil gallery
9	Oil pump
10	Oil pan
11	Intake pipe with screen
12	Channel for oil spray nozzles
13	Crankshaft bearing
14	Oil spray nozzle

From Oil Pan to Oil Pump

The oil pump (3) draws in oil from the oil pan (6) via the intake pipe with oil screen (5). The intake pipe is positioned such that the intake opening is above the oil level (4) under all operating conditions. An oil screen is integrated in the intake pipe in order to keep coarse dirt particles away from the oil pump.

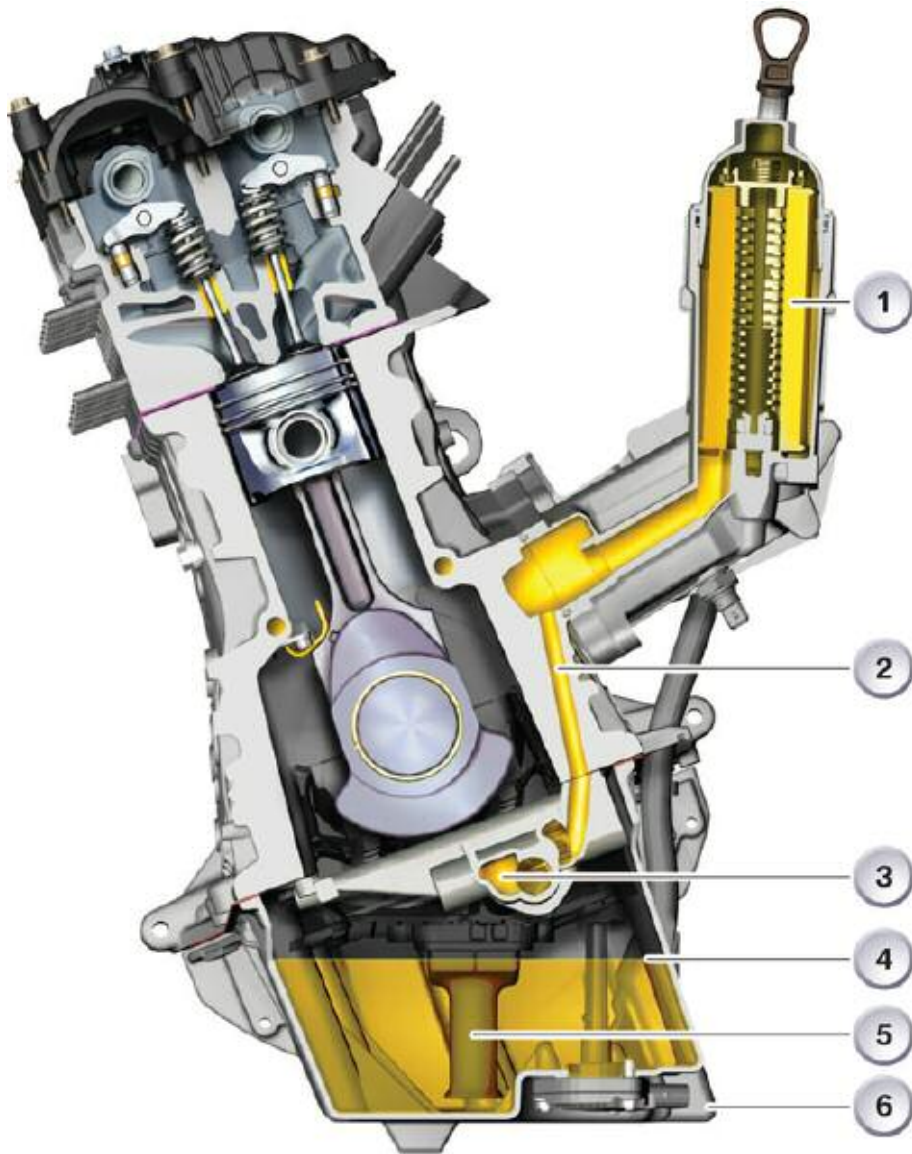

Index	Explanation
1	Oil filter
2	Unfiltered oil gallery
3	Oil pump
4	Oil level
5	Intake pipe with oil screen
6	Oil pan

Oil Pump

Different types of oil pump are used on BMW engines. On the current diesel engines, a rotor type pump is used.

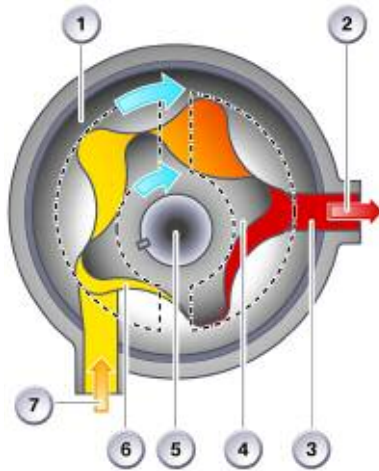

Index	Explanation
1	External gearwheel
2	Pressurized oil
3	Pressure chamber
4	Internal gearwheel
5	Driveshaft
6	Intake chamber
7	Oil intake

■ Functional Principle

The oil is drawn in by the rotor oil pump and delivered to the pressure side. The oil flows via the oil gallery (6) to the oil filter and then into the main oil gallery. The oil flows back into the oil pump housing via a filtered oil gallery (5) where it is used, for example, to supply the oil spray nozzles for piston cooling.

The control chamber of the pressure relief valve is connected to this filtered oil gallery (5) by means of a hole (4). Consequently, the system pressure in the oil circuit is also applied in the control chamber.

The control piston (2) which is actuated by compression spring (1) forms the limit on one side of the control chamber. The spring force of the compression spring (1) determines the opening pressure of the pressure relief valve.

M57 Oil Pump - Pressure relief valve closed

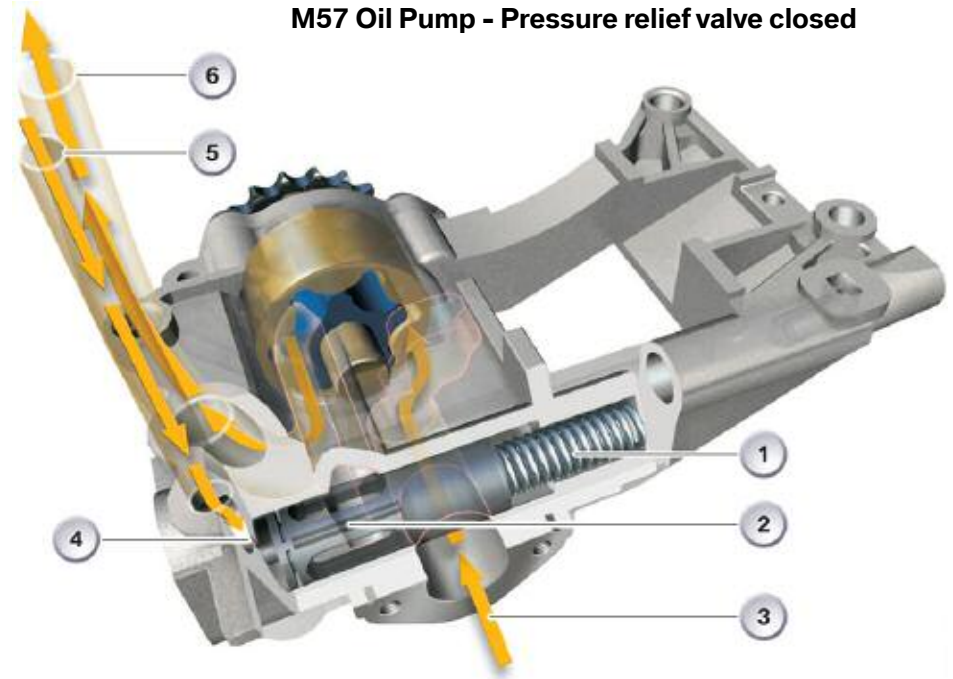

Index	Explanation
1	Compression spring
2	Control piston
3	Oil intake
4	Hole
5	Filtered oil gallery
6	Oil gallery to oil filter

The control piston (2) is moved against the spring force when the system pressure in the oil circuit, i.e. also in the control chamber, increases. The special shape of the control piston (2) opens up a connection from the pressure side of the rotor oil pump to the intake.

M57 Oil Pump - Pressure relief valve open

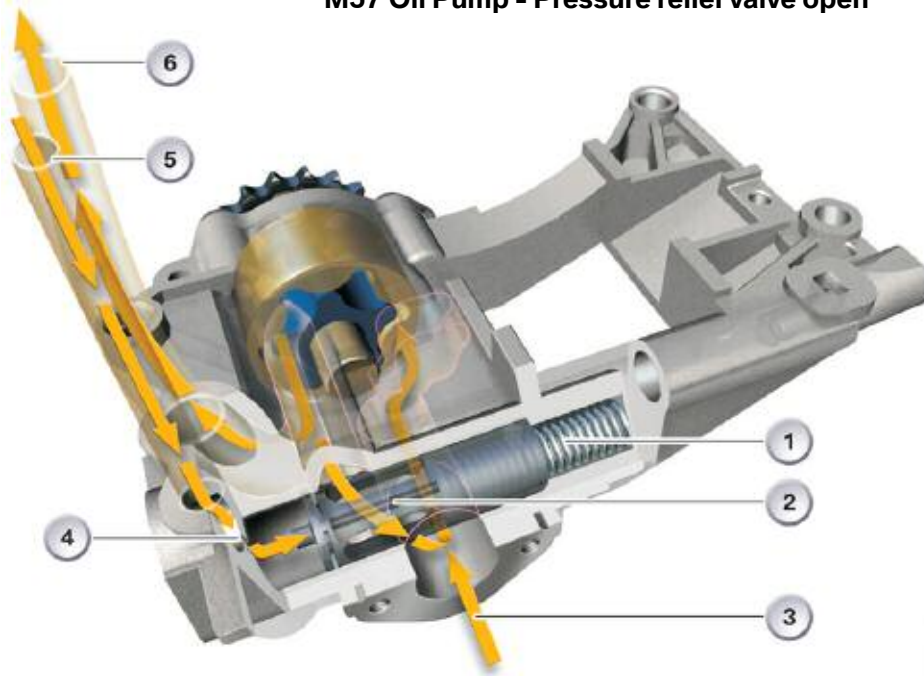

Index	Explanation
1	Compression spring
2	Control piston
3	Oil intake
4	Hole
5	Filtered oil gallery
6	Oil gallery to oil filter

The oil circuit is short-circuited. Determined by the pressure conditions, a certain quantity of oil consequently flows off from the pressure side into the intake. The greater the control piston (2) is opened, the greater the amount of oil that flows off so that the system pressure drops.

Since the control piston (2) is opened by the system pressure, equilibrium is established. In this way, a required maximum pressure in the system is now exceeded as it is determined by the force of the compression spring (1).

There are two reasons for applying oil pressure to the pressure relief valve downstream of the oil filter:

- The oil pressure actually in the system is applied and not the pressure between the oil pump and oil filter. If the oil filter were soiled, this pressure would be higher and the pressure relief valve would open before the maximum pressure were reached in the system.
- The oil is calmed in the oil filter. Consequently, the pressure relief valve is not subjected to pressure peaks thus enabling more exact valve operation.

■ Pressure Relief Valve

The pressure relief valve protects against excessively high oil pressure, e.g. when starting the engine with the oil cold. In turn this function protects the oil pump, oil pump drive, oil filter and oil cooler.

The pressure relief valve is installed on the delivery side between the oil pump and oil filter. The pressure relief valve is arranged as close as possible downstream of the oil pump, often directly in the oil pump housing.

The opening and control pressure depends on the respective type of engine and is between 3 bar and 5. Specifically, the control pressure on the M57TU2 is 4.0 bar.

Oil Filtering

The purpose of the oil filter is to clean the oil and to prevent dirt particles from entering the oil circuit. BMW diesel engines use the full-flow oil filter which allows the entire volume of oil conveyed by the oil pump to pass through the filter before it is fed to the lubrication points.

From the oil pump, the oil is fed into the oil filter module and then to the cooling system corresponding to requirement and version.

The oil filter module contains valves that fulfill various tasks, which include draining facility for filter change, filter bypass in the case of clogging and preventing the oil galleries running empty.

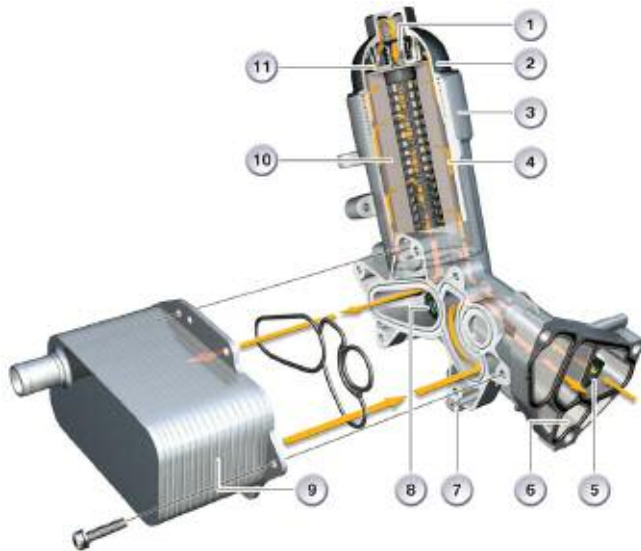

Index	Explanation	Index	Explanation
1	Filter bypass valve	7	Oil pressure switch
2	Oil filter cover	8	Heat exchanger bypass valve
3	Oil filter housing	9	Oil-to-coolant heat exchanger
4	Oil flow	10	Oil filter
5	Non-return valve	11	Oil flow via filter bypass valve
6	Oil drain opening		

The oil filter cover (2) is connected to the oil filter housing (3) by means of a long threaded stud. When the oil filter cover (2) is removed, the threaded stud releases an oil drain opening (6), via which the oil filter housing (3) can be emptied.

Note: The seals for the threaded connection of the oil filter cover must always be replaced as part of the oil service procedure. The seals are supplied together with the genuine oil filter. The screw connection for the oil filter cover must be tightened to a specified torque, which is defined in TIS.

■ Non-return Valve

The oil pump pumps the oil into the oil filter (10). A non-return valve (5) prevents the oil filter (10) draining empty when the engine is not running. This function ensures the lubrication points are supplied with oil for engine start. The oil must overcome an opening pressure in the non-return valve (5) of 0.2 bar. Drained oil galleries can cause noise or even poor engine performance shortly after starting an engine that has been stationary for a longer period of time.

■ Filter Bypass Valve

The system features a filter bypass valve (11) for the purpose of maintaining the oil supply to the lubrication points even when the oil filter (10) is soiled. If the oil pressure increases because the oil filter (10) is clogged, the filter bypass valve (11) will open at an overpressure of 2.5 bar and the oil will flow (unfiltered) to the lubrication points.

■ Heat Exchanger Bypass Valve

The heat exchanger bypass valve (8) has the same function as the filter bypass valve (11). If the oil pressure increases because the oil-to-coolant heat exchanger (9) is clogged, the heat exchanger bypass valve (8) will open at a pressure of 2.3 bar, allowing the lubricating oil (not cooled) to flow to the lubrication points.

Engine Oil Cooling

There is a risk on high-performance engines and engines subject to high thermal loads that the lubricating oil becomes too hot during vehicle operation. In this case, the viscosity decreases - the oil loses its lubricity and oil consumption increases.

This results in deposits in the combustion chamber. The oil film can break down causing bearing and piston damage. These problems can be avoided by the use of an engine oil cooler.

These additional coolers are used if the thermal losses can no longer be dissipated over the surface of the oil pan or housing so that the permitted oil temperatures would be exceeded. Oil-to-air or oil-to-coolant heat exchangers are used for the purpose of cooling the oil.

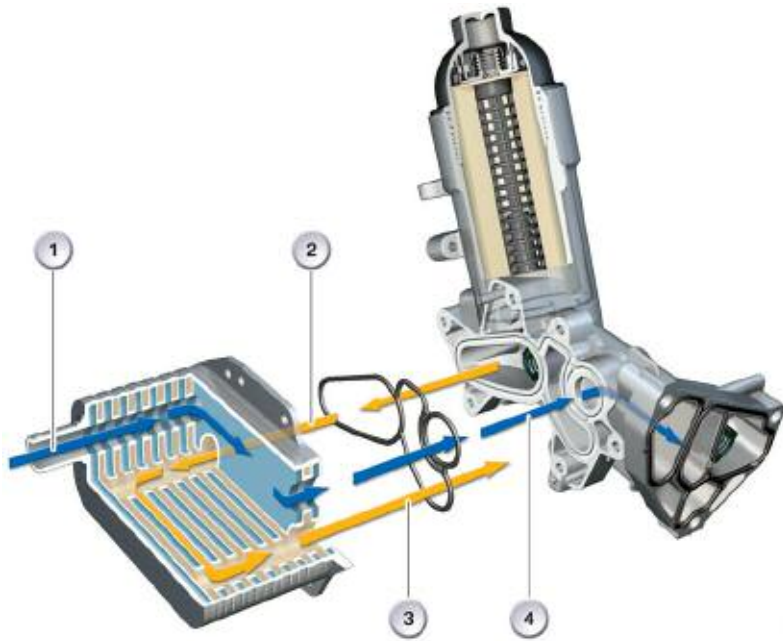

Index	Explanation	Index	Explanation
1	"Cooled" coolant	3	"Cooled" engine oil
2	"Hot" engine oil	4	Heated coolant

Oil-to-air Heat Exchanger

A conventional engine oil cooler is designed as an oil-to-air heat exchanger. This means the heat is given off from the oil to the ambient air with no further medium involved. The design of such an engine oil cooler is comparable to that of a coolant radiator.

The oil flows through the engine oil cooler with its large surface area facilitating effective heat dissipation.

Oil-to-coolant Heat Exchanger

Oil-to-coolant heat exchangers are used in the engine oil and transmission fluid heat management system. They ensure the oil heats up rapidly while sufficiently cooling the oil. Engine oil and coolant counterflows through the oil-to-coolant heat exchanger on several planes, thus transferring heat from one fluid to the other.

Oil Spray Nozzles

Oil spray nozzles are used to feed oil for lubrication or cooling purposes to defined positions of moving parts that cannot be reached via oil galleries.

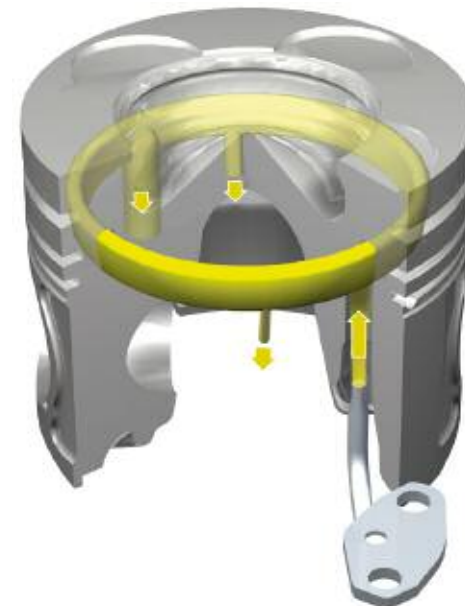



Workshop Exercise - Diesel Engine Disassembly

Using the training mockup (engine), proceed with engine disassembly using the following outline. Answer the subsequent review questions. Follow proper procedures and use repair instructions where necessary.

Remove the intake manifold, disconnect necessary hoses and connections. Leave throttle and EGR attached to the intake manifold. Also, remove the EGR cooler.

Are there any special tools required to remove the intake manifold?

What service or diagnostic procedures might require the removal on the intake manifold?

Describe the pathway for intake air. Is there anything different as compared to a gasoline engine?

How are the swirl flaps actuated?

When the swirl flaps are closed, which ports are blocked?

Remove the glow plugs.

Show and record special tools used for compression test. Explain when this would be necessary to perform.

Intake System Overview

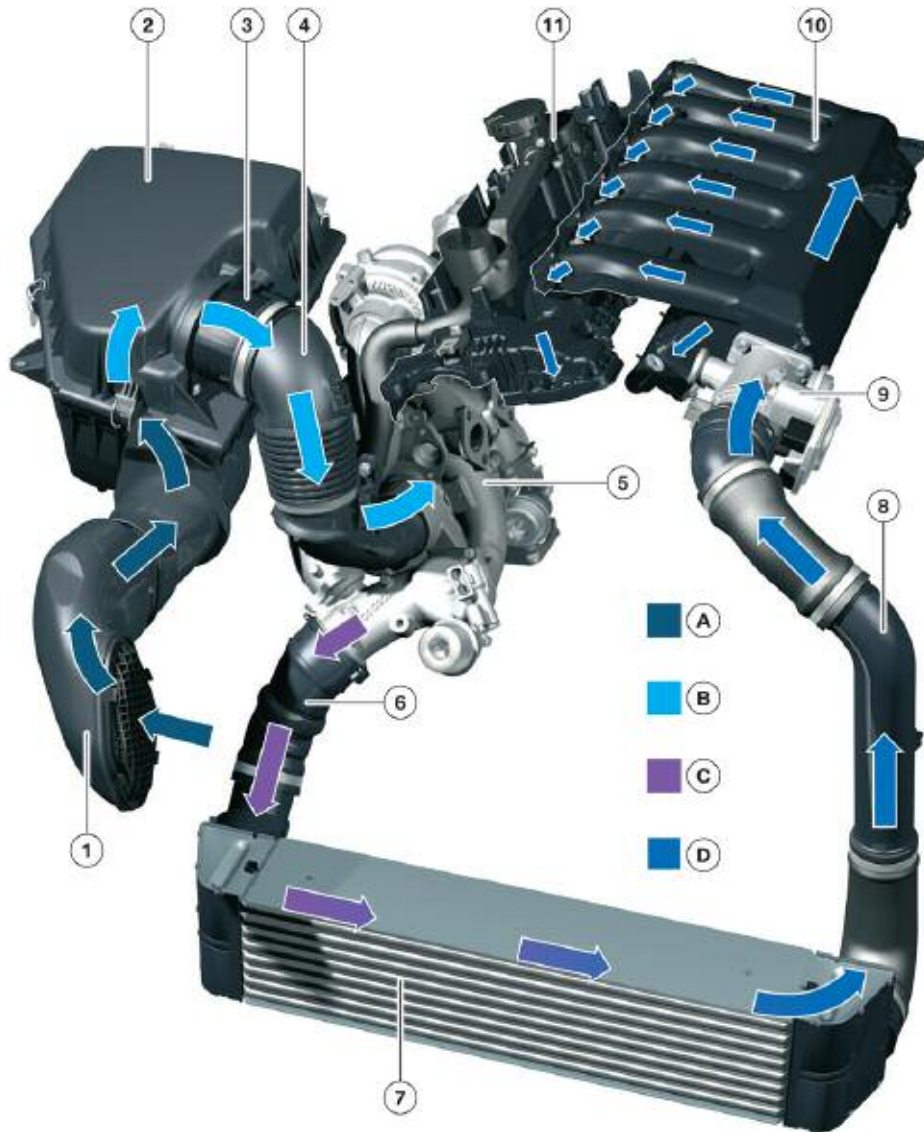

Index	Explanation
A	Unfiltered air
B	Filtered air
C	Heated charge air
D	Cooled charge air
1	Unfiltered air snorkel
2	Intake air silencer
3	Hot-film air mass meter
4	Filtered air pipe
5	Exhaust turbocharger
6	Charge-air pipe
7	Intercooler
8	Charge-air pipe
9	Throttle assembly
10	Intake air manifold
11	Valve cover with swirl ports



Workshop Exercise - Diesel Engine Disassembly

Proceed with engine disassembly. Continue by removing the fuel lines and all injectors. Pay particular attention to the installation position of the fuel lines and fuel injectors hold down brackets. Lay parts aside neatly for later installation.

Are there any special tools to remove the injectors and or leakage lines? (if so, please list them)

What special tools are used to clean the injector bores?

Demonstrate the proper use of the above tools. Have the instructor demonstrate if necessary.

Note: Take note of the o-rings and copper washer which must be replaced after removing and re-installing the injector.

Be aware that when servicing diesel fuel systems, absolute cleanliness must be observed. Cap or cover all fuel system openings. Also, use only “lint-free” cloths when cleaning any fuel system components.

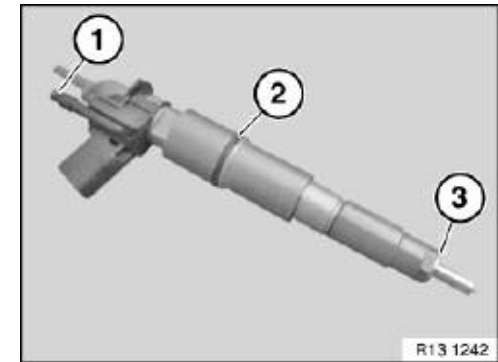

What is the purpose of the leakage lines?

Intake air flows through the cylinder head cover on this engine. What is the purpose of this design?



Workshop Exercise - Diesel Engine Disassembly

Continue by removing the crankcase vent valve from the cylinder head cover. Discuss the function and purpose of the crankcase vent valve with your instructor.

Then remove the cylinder head cover and note position of bolts and studs.

Remove the vacuum pump and set aside.

How does the vacuum pump drive mechanism differ from most current 6-cylinder gasoline engines?

Rotate the engine to the TDC position with #1 cylinder on the compression stroke. Lock crankshaft with special tool.

Check the adjustment of the intake and exhaust camshafts by using the special tools shown at the right.

Check the timing marks on the back side of the intake and exhaust camshafts.

If the adjustment is not correct, please make the necessary adjustments before removing the cylinder head.

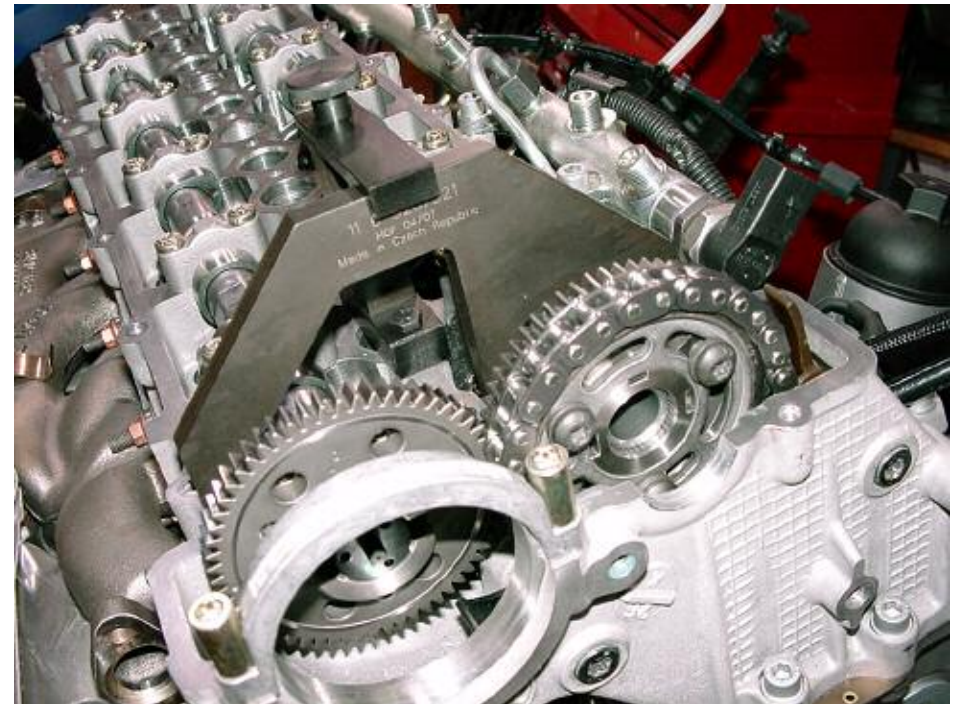



Workshop Exercise - Diesel Engine Disassembly

Prepare to remove the cylinder head. Note that both camshafts must be removed first. Remove 1 bolt (1) on intake camshaft sprocket (1st picture below). It will not be accessible when engine is rotated.

Make sure that the #1 cylinder is at TDC on the compression stroke. Note the position of the camshaft lobes. (The camshafts are counter-rotating). Continue following the instructions while observing picture sequence below.

Remove hex plug in timing case cover.

Using a wrench on the hex portion of the exhaust camshaft, rotate counter-clockwise (crank lock tool removed) a few degrees. This will allow for retraction of the timing chain tensioner piston.

Insert special tool 11 3 340 into hydraulic chain tensioner and lock in place.

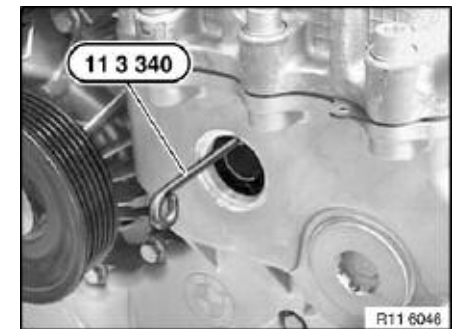
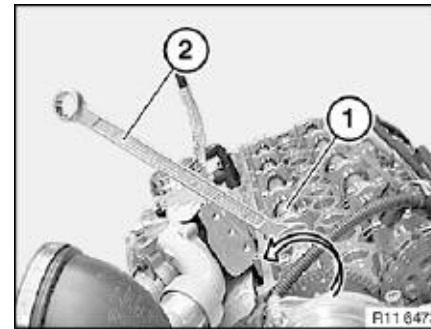
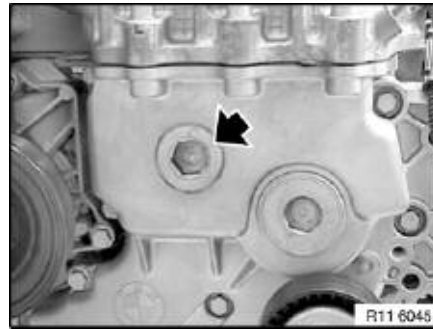
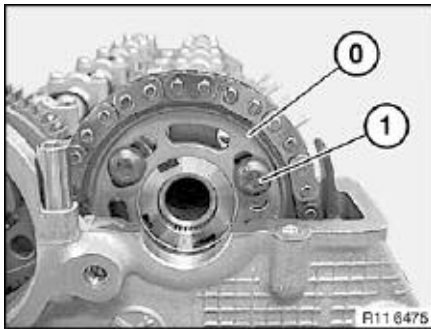

What process is used to manufacture the camshafts? _____

What is the benefit of this process? _____

Why are there are no VANOS or Valvetronic systems on this engine?



Workshop Exercise - Diesel Engine Disassembly

Follow instructions and picture sequence below.

Once the tensioner is locked, rotate the engine back to TDC and insert crankshaft locking tool.

Now that the #1 cylinder is at TDC, remove the bolts holding the timing chain sprocket on the intake camshaft.

Then, remove the bearing pins (bolts) for the timing chain guide rails.

Remove the timing chain guide rail.

Remove the timing chain sprocket from the intake camshaft.

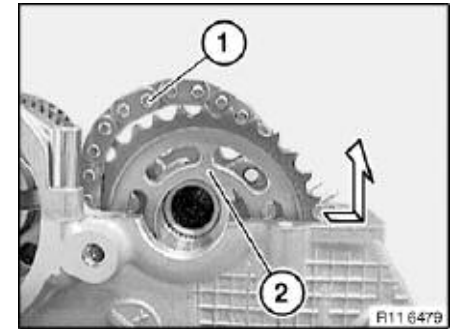
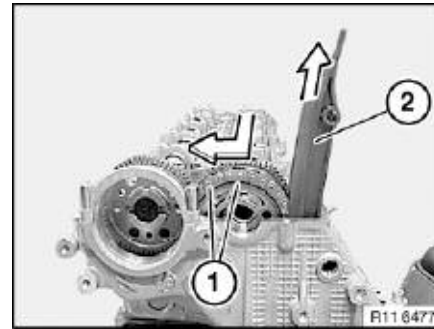
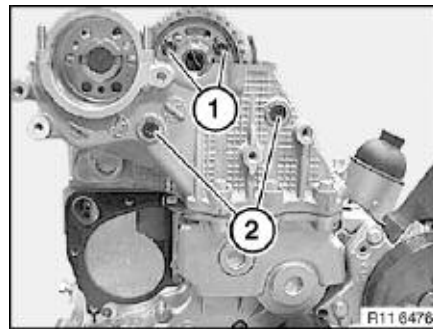
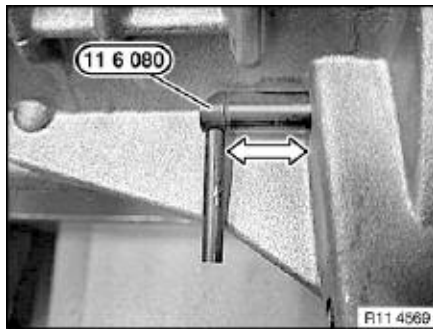

Once the timing chain sprocket is removed, continue by removing all of the camshaft journal caps. Start from the outside and work your way inside while turning bolts in small (1/2 turn) increments. Remove camshafts and set aside.

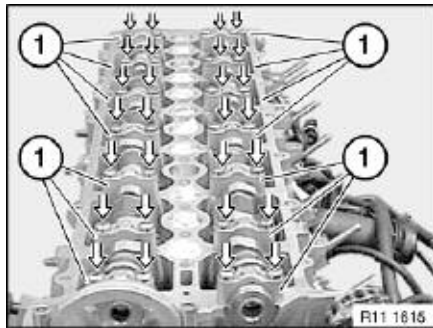

Note: Do not remove the Torx bolts shown at the right.

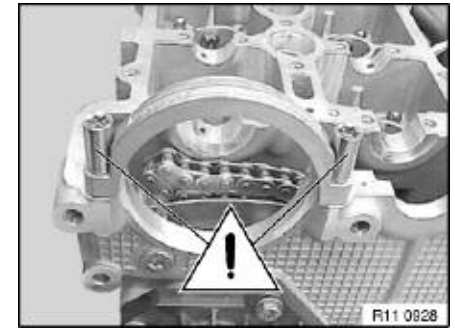



Workshop Exercise - Diesel Engine Disassembly

Before proceeding with cylinder head removal. Remove exhaust manifold and turbochargers and set aside.

Follow text and picture sequences below.

Remove all rockers (followers) and HVA elements and lay out in proper order for re-installation.

Remove hex (internal) bolts joining cylinder head to timing cover. (Be sure to remove hidden bolt as shown - 6 bolts in total)

Remove head bolts in sequence from outside to inside (in sequence from 14 to 1).

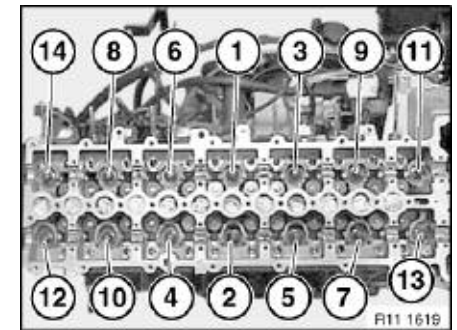
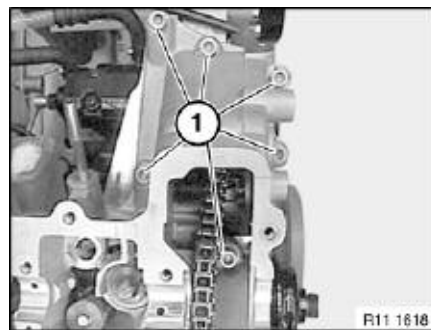
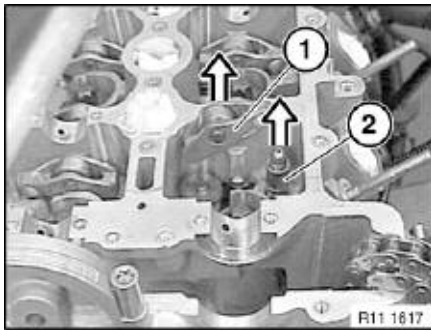

Warning: Before removing cylinder head, rotate engine counter clockwise approximately 45 degrees. This will ensure that none of the pistons are at TDC when re-installing cylinder head and camshafts.

Note: Once the cylinder head is removed, set aside. Be careful not to lay the combustion chamber surface on the bench. The glow plugs extend below the deck surface and can be damaged.

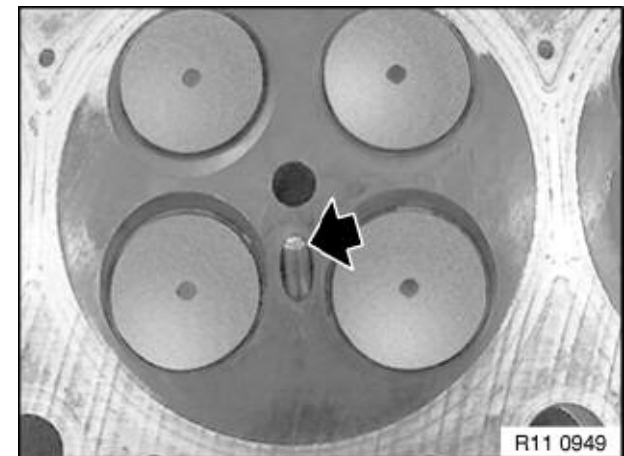



Workshop Exercise - Diesel Engine Disassembly

While the cylinder head is removed, proceed with checking piston height. Follow text and picture sequence below.

First, set the dial indicator to zero using the deck surface as a reference.

With the piston at TDC, measure the piston height at the two points indicated.

Take the highest of the two measurement points. Refer to chart to select correct head gasket. Fill in chart with your results.

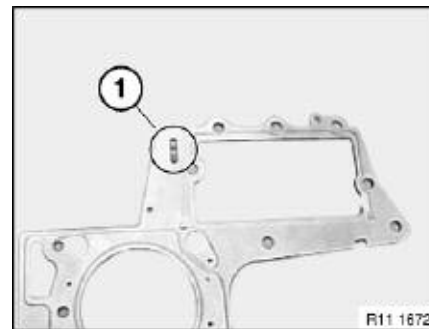
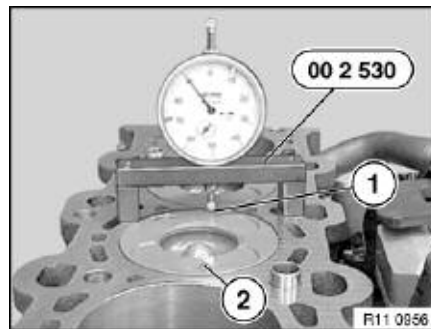
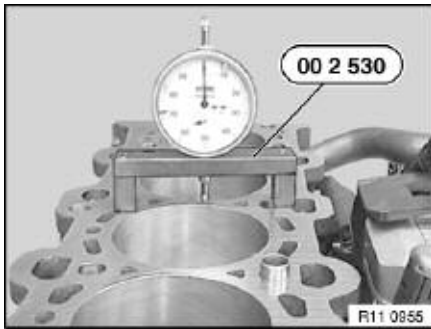

Cylinder	1	2	3	4	5	6	Highest Measurement
Piston height 1							
Piston Height 2							

Piston Clearance	Gasket Selection
<i>Less than 0.92 mm</i>	One Hole
<i>Between 0.92 and 1.03</i>	Two Hole
<i>Above 1.03 mm</i>	Three Hole

When would it be necessary to check piston height?



Workshop Exercise - Diesel Engine Disassembly

Rotate engine 180 degrees (oil pan side - up), remove oil pan (sump).

Once the oil pan is off, remove oil pump pickup tube and oil pump.

What type of oil pump is used in this engine?

How is the oil pump controlled?

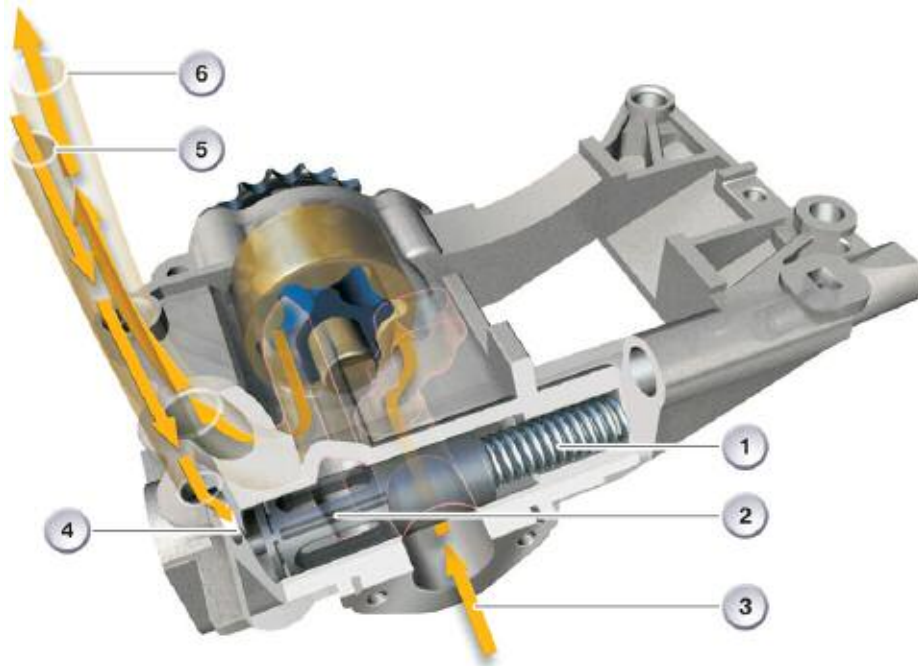

Index	Explanation
1	Compression spring
2	Control piston
3	Oil intake
4	Hole
5	Filtered oil gallery
6	Oil gallery to oil filter



Workshop Exercise - Diesel Engine Disassembly

Proceed by removing one piston and rod assembly. Use proper tools to protect crankshaft journals.

Describe the type of connecting rod and the manufacturing process:

Remove the connecting rod bearing shells from the connecting rod. Locate the shell which has an “S” stamped on it.

What does the “S” designation indicate and where is it installed?

Remove 1 main bearing cap and note “embossed” technique for alignment.

Re-install main cap using proper procedures.

Then, remove timing cover and note timing chain arrangement and arrangement of hydraulic tensioners.

Is it possible to remove the high pressure fuel pump without removing the front timing cover ? (explain)

Re-install piston and rod assembly using special tools.

Re-install timing chain cover, oil pump and pickup.

Rotate engine and prepare to re-install cylinder head. Do not install oil pan at this time.



Workshop Exercise - Diesel Engine Disassembly

Inspect all dowel pins and install correct cylinder head gasket.

Follow text and picture sequences below.

Install head bolts and torque in sequence from inside to outside (in sequence from 1 to 14).

(Note: Do not torque to maximum for training engine - only use jointing torque)

Install hex (internal) bolts joining cylinder head to timing cover. (Be sure to install hidden bolt as shown - 6 bolts in total)

Install all rockers (followers) and HVA elements in the same position from which they were removed. (Hint: used rockers and HVA elements should only be installed on the same camshaft lobe to prevent premature wear).

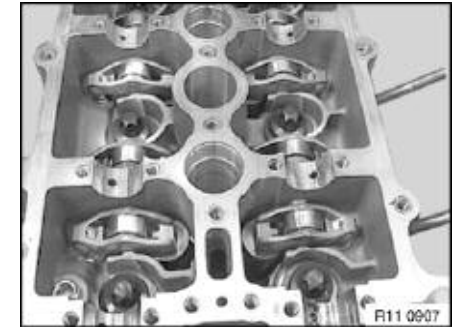
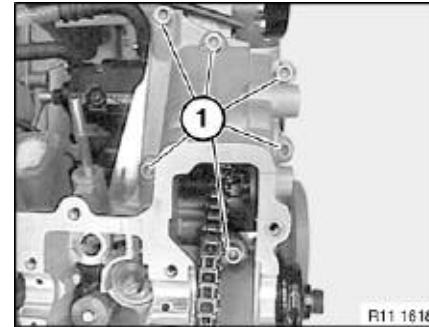
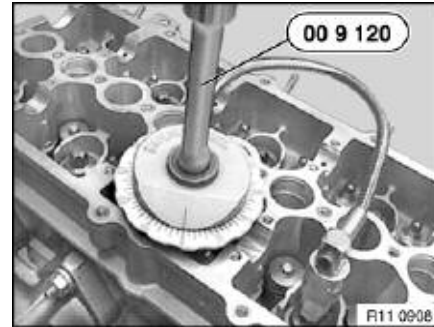
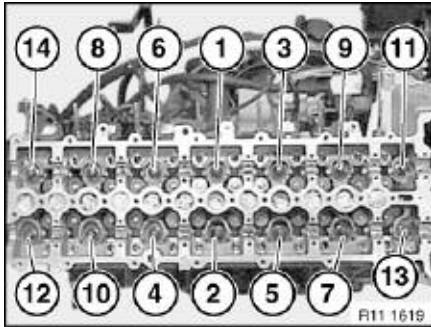

Record cylinder torque specifications and sequence in the chart below:

Step 1	Step 2	Step 3	Step 4
Jointing Torque	Loosen	Jointing Torque	Final - Angle Torque



Workshop Exercise - Diesel Engine Disassembly

Once the cylinder head is installed, proceed with camshaft installation. Make sure the engine is rotated counter-clockwise about 45 degrees to prevent valve to piston contact when installing camshafts.

Follow text and picture sequences below.

When installing intake and exhaust camshafts, be sure to align the camshaft lobes as shown (to the right when viewing from rear of engine)

Align marks on camshafts as shown. Intake and exhaust camshaft markings must be meshed.

Install bearing caps on camshafts and tighten from inside to outside in small increments.

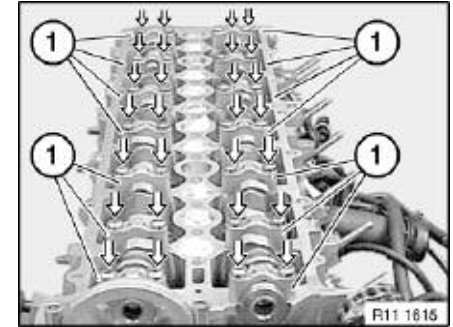
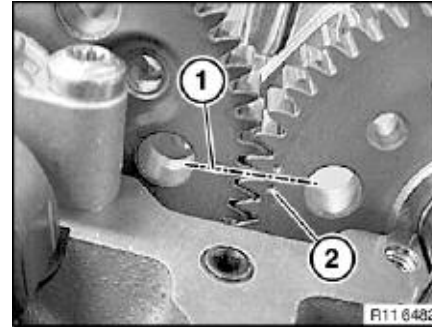
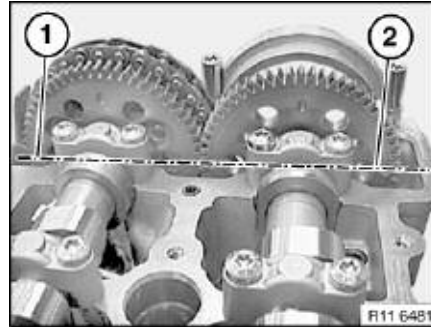
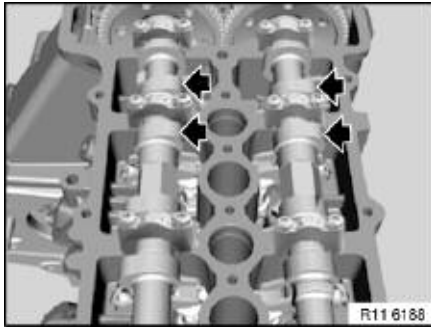

Once the camshafts are installed, set up special tool as shown and check axial play on the intake camshaft. (.02 to .150mm)

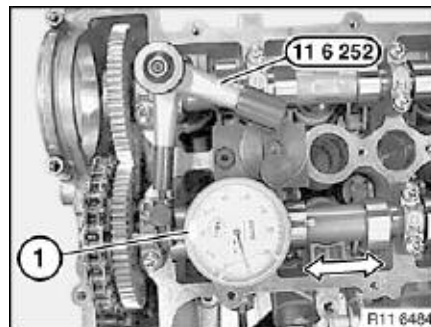
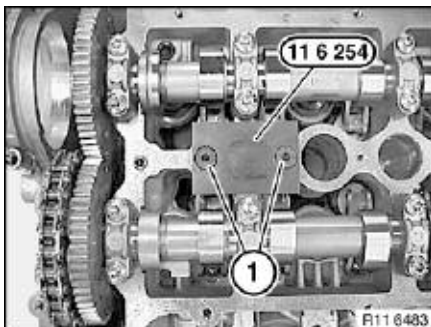



Workshop Exercise - Diesel Engine Disassembly

After the cylinder head and camshaft installation is complete, reinstall timing chain, chain guides and camshaft sprocket.

Prepare to set and adjust camshaft timing.

Lock engine at TDC using special tool.

Loosen camshaft sprocket bolts. Note - 3rd camshaft sprocket bolt is not installed at this time.

Install special tools and check (set if necessary) camshaft timing. Tighten camshaft sprocket bolts to proper torque. Rotate engine 360 degrees and re-install 3rd sprocket bolt and tighten to specification. Rotate engine another 360 degrees and re-check timing.

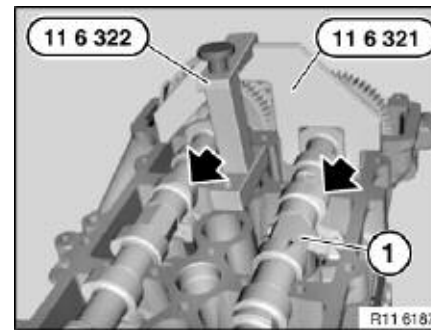
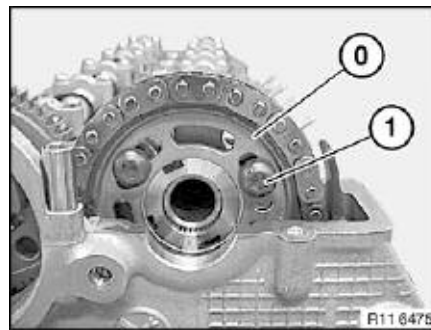
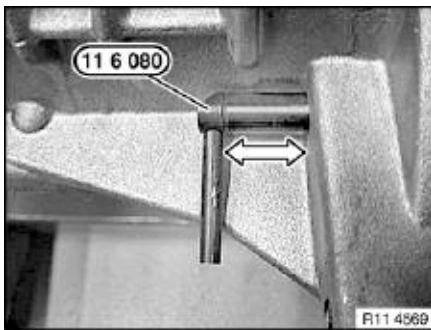

Re-install Cylinder head cover and tighten bolts in sequence from inside to outside. Use correct specification from TIS. In the field, be sure to use anaerobic sealer (Drei-bond) where shown (picture 3 at point 1).

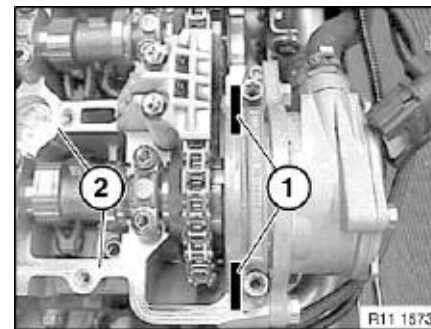
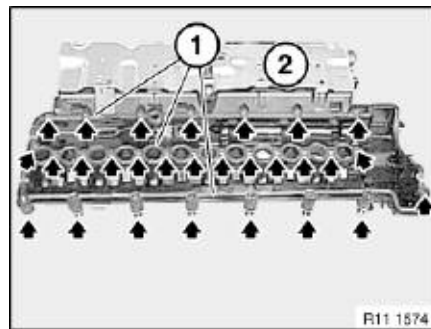
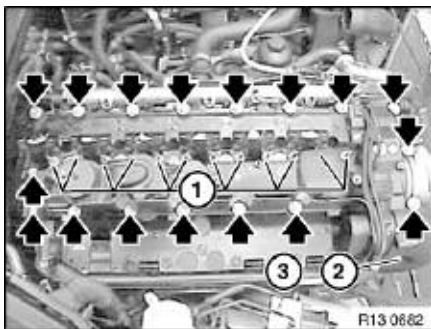



Workshop Exercise - Diesel Engine Disassembly

Install all fuel injectors, fuel rail and fuel lines. Pay particular attention to the torque specification on the fuel system components. When working with the fuel system components, absolute cleanliness must be observed to avoid any fuel system malfunctions. Note the 7-digit codes on the fuel injectors. The injectors must be returned to the same cylinders from which they were removed. The injectors codes must be entered into the diagnostic system if replaced.

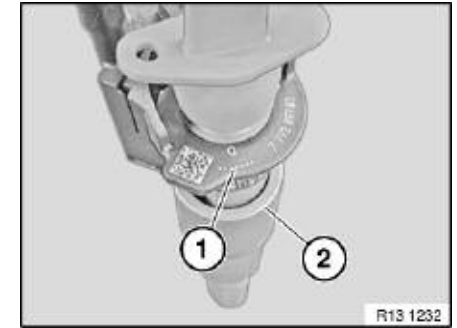
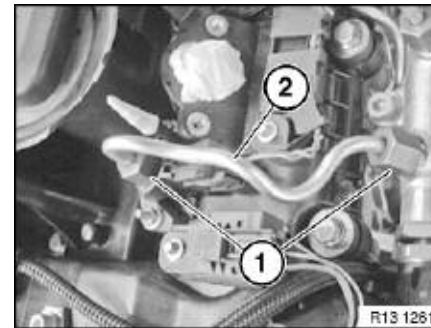
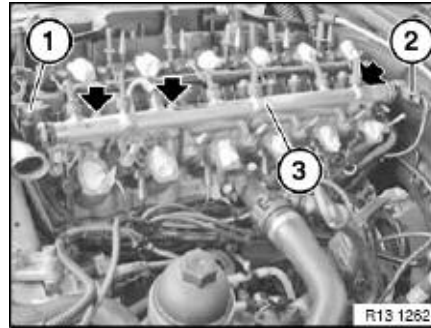
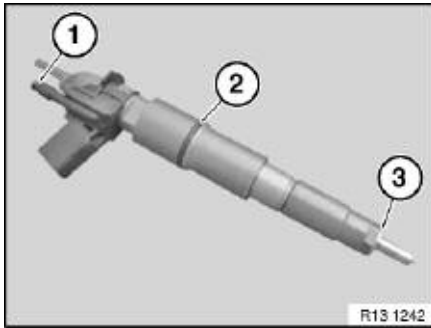

Fill in the chart below with the correct torque specifications for the fuel injectors and lines:

Note: The injector lines must not be over-tightened. The diameter of the fuel line can be reduced, resulting in a loss of power from the reduction in fuel flow.

Torque	Injector Hold down to valve cover	Fuel line (Injector)	Fuel line (on high pressure pump)	Fuel line (Fuel rail/accumulator)
Newton Meters				

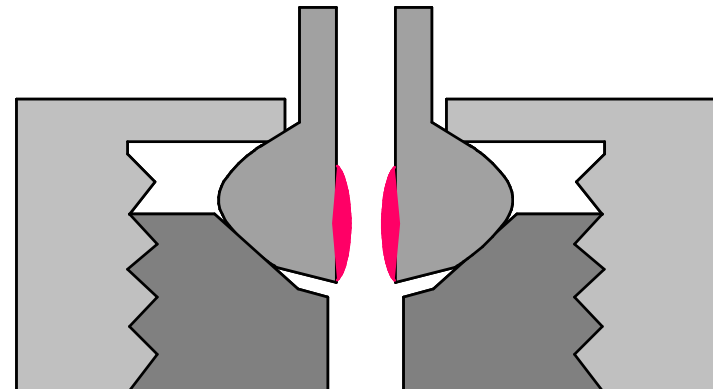



Workshop Exercise - Diesel Engine Disassembly

Re-install exhaust manifold/turbochargers. Tighten bolts to specification.

Re-install glowplugs, EGR cooler and thermostat. Re-install vacuum pump. (Do not install intake manifold at this point)

Rotate engine and install oil pan, tighten bolts to specification in sequence.

Complete engine assembly by installing all engine accessories, vacuum lines and hoses.

*With the engine assembled, proceed with the removal of the high pressure fuel pump using the special tools.
(This simulates removal in the vehicle).*

Follow text and picture sequence below:

Remove intake manifold (should already be removed).

Disconnect electrical plug at pump (1).

Remove fuel feed line and return (2 and 3).

Remove high pressure fuel line between pump and rail (4). Replace high pressure line.

Open plug in timing cover.

Remove nut (1) on timing gear sprocket .

Install special tool as shown.

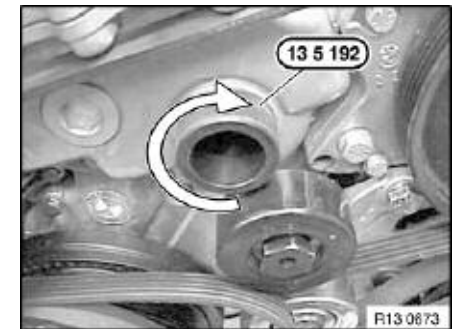
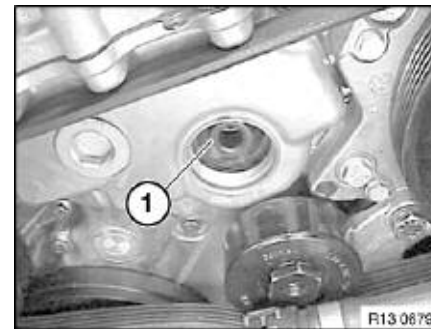
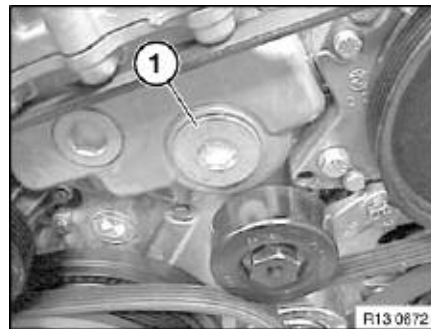
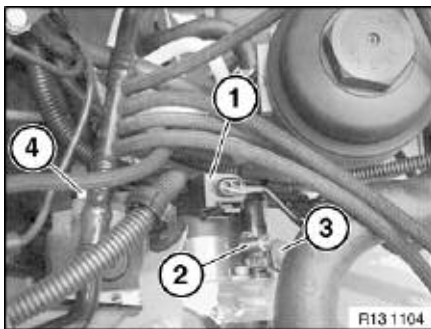



Workshop Exercise - Diesel Engine Disassembly

Install special tool (135191) with jack screw backed out. Threaded portion of tool should lock into sprocket.

Remove the three nuts (1) holding fuel pump to crankcase.

Tighten jack screw until high pressure pump is released from from sprocket.

Note - pump shaft has keyway (woodruff key), be sure to take this into account during re-installation.

Replace pump gasket if necessary.

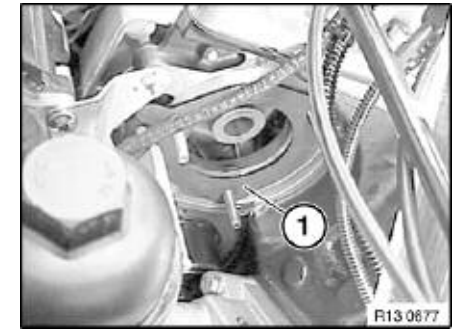
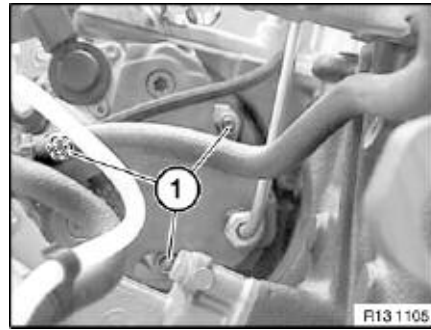
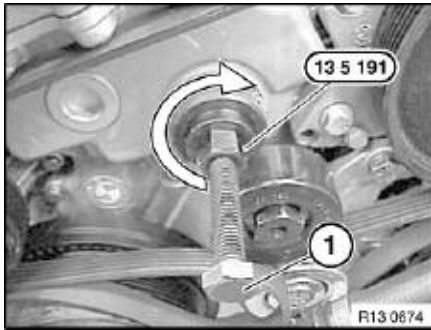

Reverse procedure to re-install high pressure pump. Be wary of keyway on fuel pump shaft.

Once complete, re-install intake manifold and necessary accessories, lines and hoses.



Classroom Exercise - Review Questions

1. Special tool 11 6 080 is used to:
Select the BEST possible answer
 - A. Remove the high pressure fuel pump
 - B. Lock the crankshaft at TDC
 - C. Align the camshafts for timing check
 - D. Lock the hydraulic tensioner

2. If your piston clearance is between 0.92 and 1.03 mm, you should use a head gasket with:
Select the BEST possible answer
 - A. No holes
 - B. One hole
 - C. Two holes
 - D. Three holes

3. The intake valves on a diesel engine are:
Select the BEST possible answer
 - A. sodium filled
 - B. the same diameter as the exhaust valves
 - C. larger than the exhaust valves
 - D. not used on a diesel engine

4. Which of the following BEST describes the manufacturing process of the camshafts on the M57D30T2 engine?
Select the BEST possible answer
 - A. Hydroformed
 - B. Cast iron
 - C. Presta process
 - D. Forged steel

5. Which of the following statements is NOT true regarding the crankcase on the BMW diesel engine (M57D30T2)?
Select the BEST possible answer
 - A. The cylinder bores are cast iron sleeves
 - B. The deck surface is “closed”
 - C. The crankcase is made from aluminum
 - D. The block used a bedplate for rigidity

6. The swirl flaps, when closed, block:
Select the BEST possible answer
 - A. The swirl port
 - B. The EGR passage
 - C. The tangential port
 - D. The exhaust port
 - E. The crankcase ventilation



Classroom Exercise - Review Questions

7. Which special tool is used to clean the injector bores on the diesel engine?
- Select the BEST possible answer**
- A. 002 530
 - B. 13 0 590
 - C. 13 5 190
 - D. 13 5 210
8. The torque specification for the fuel lines on the common rail system is:
- Select the BEST possible answer**
- A. 11 Nm
 - B. 17 Nm
 - C. 19 Nm
 - D. 23 Nm
9. The axial play in the intake camshaft is:
- Select the BEST possible answer**
- A. .01 to .05 mm
 - B. .02 to .150 mm
 - C. .03 to 0.25 mm
 - D. .04 to 0.025 mm
10. The torque angle tool for the cylinder heads is P/N:
- Select the BEST possible answer**
- A. 00 9 120
 - B. 00 2 150
 - C. 00 1 100
 - D. 00 5 600
11. When installing and removing the cylinder head, it is advised to rotate the engine _____ to prevent valve to piston contact.
- Select the BEST possible answer**
- A. About 45 degrees counter clockwise from TDC
 - B. About 90 degrees clockwise from TDC
 - C. 180 degrees clockwise from TDC
 - D. About 120 degrees counter-clockwise from TDC

Diesel Engine Management

In comparison to the first BMW diesel engine, the M21D24, modern diesel technology has evolved considerably throughout the past 20 years. The early engines were not “managed”, that is to say that there were only minimal electronic systems involved. The injectors were mechanical and there were no feedback systems in place such as O₂ sensors etc.

Modern diesel engines have benefitted from the advances in current gasoline engine management technology. The Digital Motor Electronics (DME) systems have been adapted to the needs of the diesel engine in the form of Digital Diesel Electronics (DDE).

DDE systems constitute many of the same components and systems as their gasoline powered “cousins”. Some of the familiar items include electronically controlled injectors, O₂ sensors as well as other common sensors including crankshaft and camshaft sensors.

The main goals of DDE include the reduction of emissions and maximization of engine efficiency and fuel economy. Also, the ability to have more precise control of the injection process allows modern diesel engines to have reduced noise emissions. Engine noise has long been a negative aspect of diesel engines.

The Digital Diesel Electronics (DDE) systems have gone through a progression of enhancement and improvements since the first DDE system was introduced on the M21 engine.

The early development of DDE systems began with the M21D24 engine in 1987. The first generation of diesel engine management was referred to as DDE 1. Over the past 20 years of development, the DDE has seen numerous improvements in processing speed and computing power.

These advancements have allowed for more precise control over the fuel injection system. This precise control has allowed for a significant reduction in emissions and a considerable improvement in fuel economy. Soot, smoke, NO_x have all been reduced by optimizing the injection strategy.

The current generation of DDE systems are referred to as DDE 6X. For example the M57TU1TOP engine for European markets uses DDE version 606 and 626. Other engines in use in European markets such as the latest 4-cylinder diesel take advantage of DDE7.

For the purposes of this training module we will be referring to version DDE 6X.

Engine Control Module (DDE)

The ECM is the computational and switching center for the DDE system. Sensors installed on the engine and in the vehicle provide the input signals for the DDE.

Actuators execute the commands of the DDE. The DDE calculates the necessary control signals for the actuators from the input signals together with the computational models and characteristic maps stored in the DDE.

DDE operation is guaranteed with a system voltage of between 6 V and 16 V. An ambient pressure sensor and a temperature sensor are integrated in the DDE.

The ambient pressure sensor makes it possible for the density of the ambient air to be precisely determined - a variable that is used in numerous diagnostic functions. Furthermore, it is needed if the cylinder charge is being calculated from the substitute variables in the event of a hot-film air mass meter fault, for example.

The temperature sensor measures the temperature inside the control unit. If the temperature there increases to excessively high levels, the multiple injection, for example, is reduced in order to cool down the output stages a little and to maintain the temperature inside the control unit within a non-critical range.



DDE I-P-O Chart (Typical)

Typical DDE System

DDE 606
M57TU1TOP
(Not for US Market)

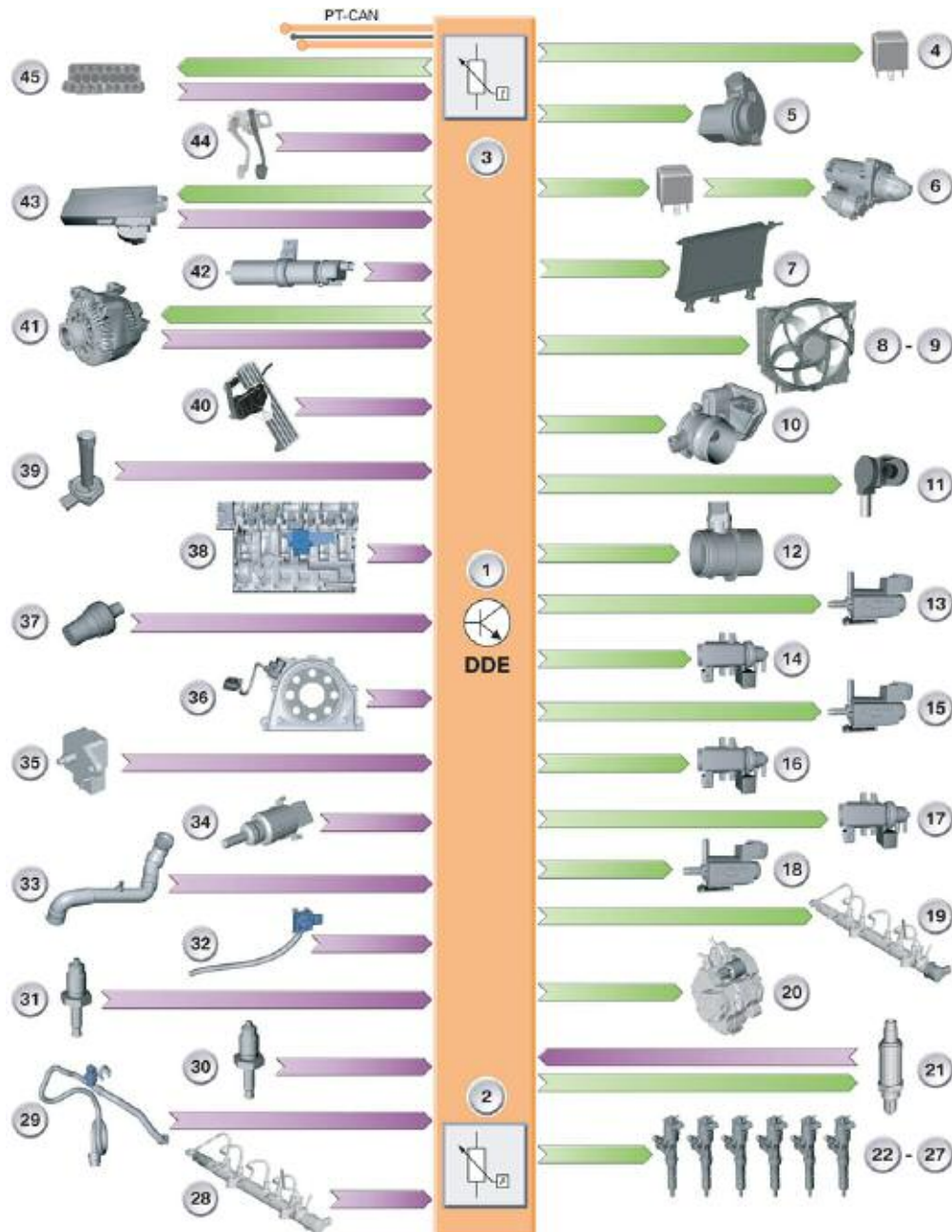

Index	Explanation	Index	Explanation
1	Digital Diesel Electronics (DDE)	22-27	Fuel injectors
2	Ambient pressure sensor in control unit	28	Rail pressure sensor
3	Temperature sensor in control unit	29	Fuel temperature sensor
4	DDE Main relay	30	Exhaust gas temperature sensor 1
5	E-box fan	31	Exhaust gas temperature sensor 2
6	Starting relay with starter	32	Exhaust pressure sensor
7	Auxiliary heater	33	Intake air pressure sensor
8-9	Electric fan with fan control	34	Coolant temperature sensor
10	Throttle valve actuator	35	Boost pressure sensor
11	Camshaft position sensor	36	Crankshaft position sensor (KWG)
12	Hot-film Air Mass Meter	37	Oil pressure switch
13	Electric changeover valve (EUV) for engine mount control	38	Preheating control unit
14	Electro-pneumatic pressure converter (EPDW) for exhaust gas recirculation (EGR)	39	Oil level sensor (Töns or QLT)
15	Electro-pneumatic pressure converter (EPDW) for turbine control valve	40	Accelerator pedal module
16	Electro-pneumatic pressure converter (EPDW) for wastegate	41	Alternator
17	Electric changeover valve (EUV) for compressor bypass valve	42	Diagnosis line for fuel filter heating
18	Electric changeover valve (EUV) for swirl flaps	43	Car Access System
19	Rail pressure control valve	44	Brake light switch
20	Volume control valve	45	On-board diagnostics socket
21	Broadband oxygen sensor (LSU 4.9)	46	Ground connection

Sensors and Actuators

Sensors

- Accelerator pedal module
- Hot-film air mass meter (HFM)
- Boost pressure sensor
- Coolant temperature sensor
- Fuel temperature sensor
- Rail pressure sensor
- Charge air temperature sensor
- Camshaft position sensor (NWG)
- Thermal oil level sensor (TÖNS)
- Crankshaft position sensor (KWG)
- Exhaust pressure sensor
- Exhaust gas temperature sensor upstream of DOC
- Exhaust gas temperature sensor upstream DPF
- Oxygen sensor Bosch LSU 4.9 with constant characteristic

Actuators

- Fuel injectors 1-6
- Volume control valve
- Pressure control valve
- Electric changeover valve (EPDW) for exhaust gas recirculation
- Electric changeover valve (EUV) for swirl flaps
- Electric changeover valve (EUV) for engine mounts
- E-box fan

- Electric motor throttle valve actuator
- Electro-pneumatic pressure converter (EPDW) for turbine control valve
- Electro-pneumatic pressure converter (EPDW) for wastegate
- Electric changeover valve (EUV) for compressor bypass valve

Switches

- Brake light switch/brake light test switch
- Oil pressure switch
- Clutch switch

Relays

- DDE main relay
- Starter relay

Interfaces

- Bit-serial data interface BSD (alternator, preheating control unit)
- PT-CAN

Electro-pneumatic Pressure Converter (EPDW)

(EPDW) apply vacuum to the diaphragm units of the turbine control valve and wastegate. The DDE uses a PWM signal (300 Hz) to actuate the EPDW. The nominal voltage is 12 V.

Electric Changeover Valve (EUV)

An electric changeover valve (EUV) applies vacuum to the diaphragm unit of the compressor bypass valve. The DDE controls the EUV. The nominal voltage is 12 V.

NOTES

PAGE

Diesel Fuel Systems

There are two basic types of diesel injection methods used on BMW diesel engines. The early designs such as the M21 utilized the indirect injection (IDI) method (swirl chamber) which injects fuel into a pre-chamber rather than directly into the combustion chamber. Modern designs take advantage of direct injection (DI) which, as the name suggests, injects fuel directly into the combustion chamber.

Indirect injection (IDI) can be broken down further into two groups. The “pre-chamber” design and the “swirl” (or turbulence) chamber design. As far as BMW current BMW diesel vehicles are concerned, the direct injection arrangement on the diesel is only used with common rail injection systems. Common rail was first introduced into BMW production diesels on the M57 family engines for the 1999 model year.

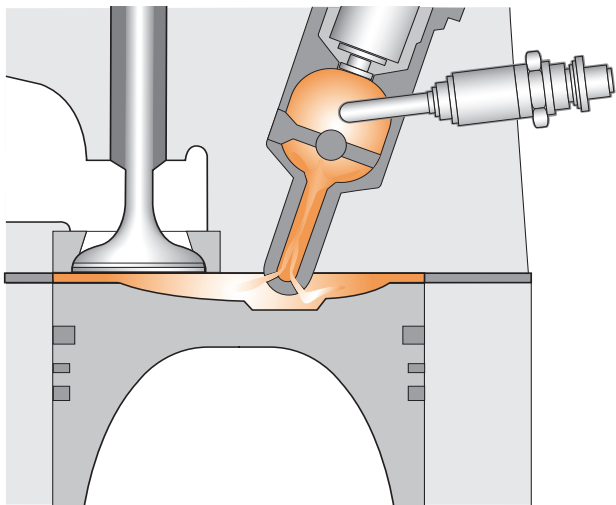

“Pre-chamber” design (IDI)

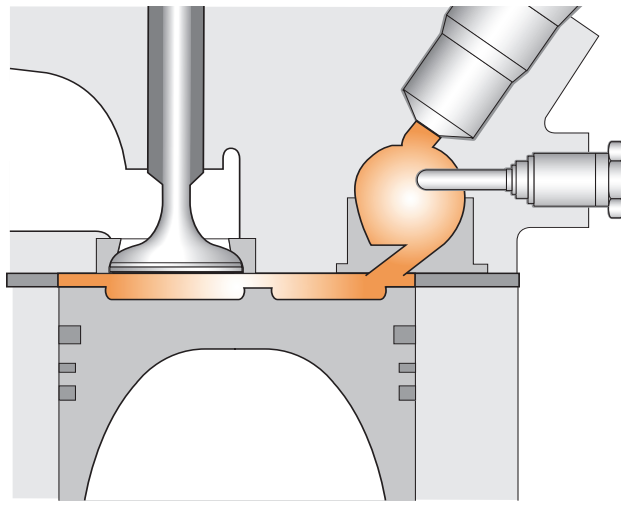

“Swirl-chamber” design (IDI)

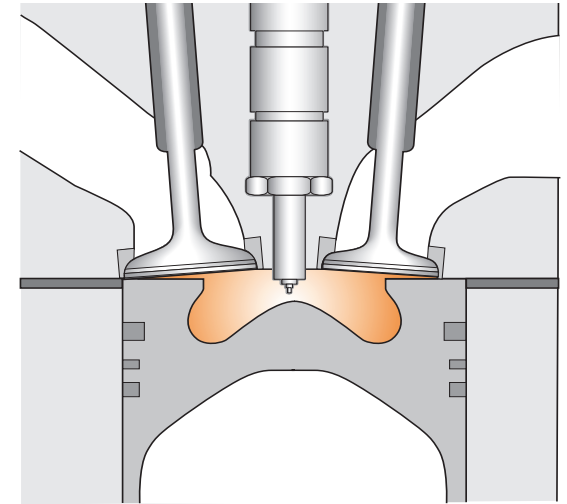

“Direct Injection” design (DI)

The indirect method of injection was very popular on early engine designs such as the M21. The IDI systems offered advantages in emissions and engine noise reduction. Today, direct injection designs have replaced the IDI systems. This is due to the advanced high pressure common rail systems currently available. With electronic controls and high pressure injection, the new common rail systems have paved the way for direct injection to offer up to 20% fuel savings over the earlier designs.

Now, with Digital Diesel Electronics (DDE) from BMW, the latest common rail systems are capable of providing multiple injection events. There is now the possibility of “pre” and “post” injection events. The pre-injection phase allows for a significant reduction in engine noise as compared to the earlier IDI systems.

Distributor Type Diesel Injection

In order to understand how far diesel fuel injection technology has come, it is important to understand the fuel system which was used in the “early days” of BMW diesel development. The M21 engine used a mechanical injection system which had only minimal electronic intervention. The main method of engine control was the fuel pump which was a “distributor type”. This meant that the fuel pump was responsible for creating the high pressure needed as well as the injection timing and distribution of the pressurized fuel to each cylinder.

Each of the fuel injectors on this system was mechanical, which means that the opening of the injector was pressure dependent. These injectors would open at a pressure of about 150 bar (2175 psi). This pressure was provided by the distributor injection pump at a specific time, this timing was crucial to engine operation. Much like the ignition timing on a “spark-ignition” engine, the timing of these events was vital to proper engine operation.

On the M21, the distributor type pump was mechanically driven by the engine, via the timing belt. This pump needed to be adjusted mechanically to ensure proper timing of the fuel injection events. This engine was quite efficient for its time, however ever increasing emission legislation and fuel economy concerns drove the development of the future common rail injection systems.

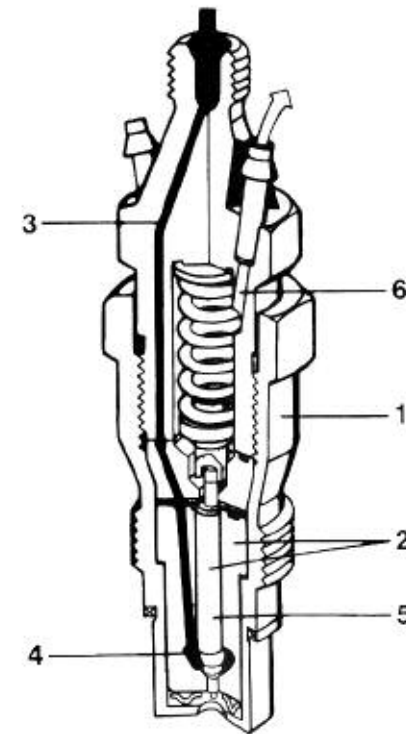
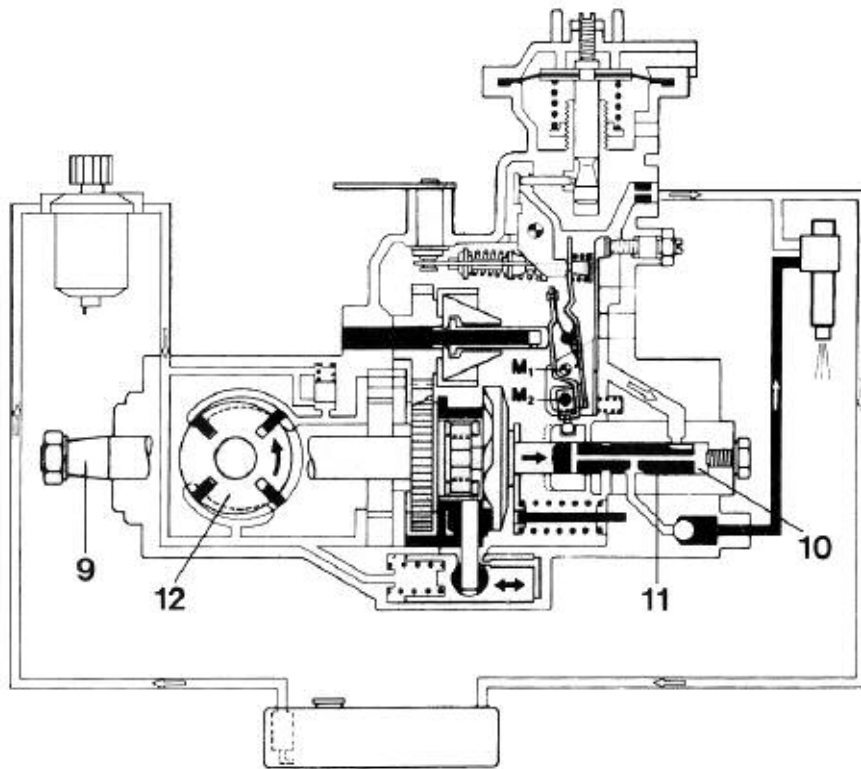

Common Rail Fuel Injection

The common rail fuel system is divided into two parts - the low pressure system and the high pressure system. The low pressure system is responsible for supplying the high pressure mechanical fuel pump. The low pressure portion of the fuel system will be discussed in the subsequent pages.

The high pressure system is responsible for the fuel pressure generation required to supply the fuel injectors via the common rail.

The latest common rail technology is capable of generating injection pressures of more than 1600 bar (23,200 psi) and in some new systems up to 1800 bar (26,100 psi). The system is also capable of varying pressure as needed independently of injection timing and injection quantity.

The use of electronically controlled fuel injectors allows for more precise control over exhaust emissions and noise characteristics. The engine noise or “clatter” which is usually associated with diesel engines is greatly reduced by the modern common rail injection system.

Common rail systems are referred to as “accumulator” systems due to the use of a fuel rail. The fuel rail stores pressurized fuel for use by the injectors. This type of system resembles a modern gasoline (direct) fuel injection system, but operates at considerably higher rail pressures.

From the inception of common rail systems, enhancements have been made to improve performance and emission levels. Current BMW vehicles are using the “3rd Generation” of common rail systems. These systems include such innovations as piezo-electric injectors, multiple injection phases and high-pressure CP3 (plus) pump.

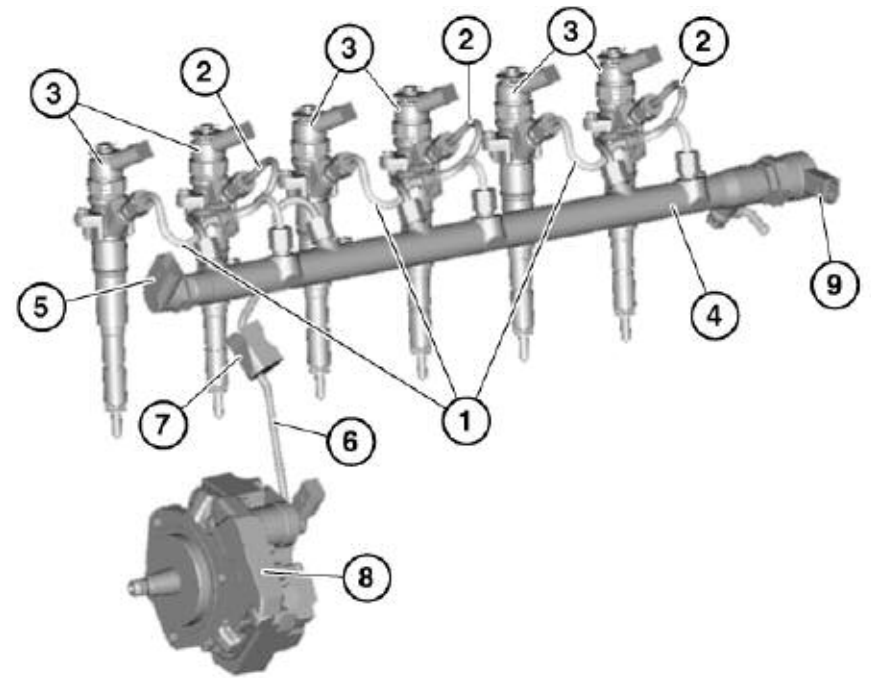

Index	Explanation	Index	Explanation
1	High-pressure fuel lines (cylinders 1, 3 and 5)	6	High pressure fuel line (pump to rail)
2	High-pressure fuel lines (cylinders 2, 4 and 6)	7	Rubber mount for fuel line
3	Fuel injectors	8	High-pressure fuel pump (CP 3.2 plus) w/volume control valve
4	Fuel rail (accumulator)	9	Pressure control valve
5	Rail pressure sensor		

Common Rail System Components

High Pressure Fuel Pump

The fuel pump used on common rail systems is a radial, piston type pump containing three pistons. The pump is mechanically driven via the engine timing chain. It is a volume controlled high pressure pump commonly known as the CP3.2+ (Bosch).

The delivery volume for this design is 866 mm³, which is greater than the previous generation (CP 3.2).

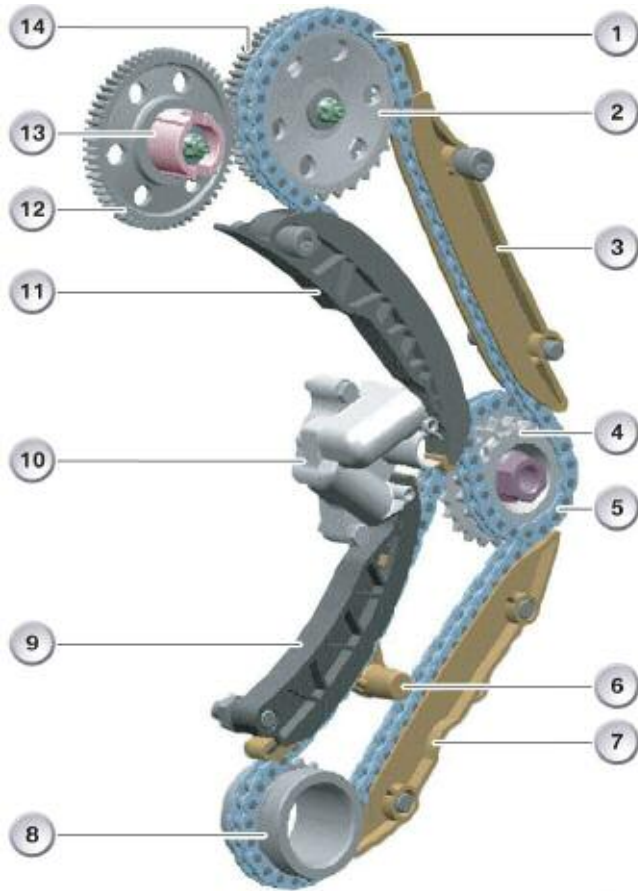

■ Functional Principle

The electric fuel pump supplies fuel to the high pressure pump via the feed line (1). The high pressure pump consists of three pistons that are raised by a common triple cam (7). Springs press the pistons against the drive cam.

Each cylinder of the high pressure pump features ball valves for fuel inlet and outlet. The volume of fuel calculated by the DDE flows via the volume control valve (2) into the cylinders of the high pressure pump.

During the downward stroke of the pistons, the fuel flows from the volume control valve into the cylinders of the high pressure pump. Due to the downward movement of the pistons, the fuel is delivered at high pressure into the rail (4).

The drive cam is lubricated by the diesel fuel. For lubrication purposes, a quantity of the fuel flows from the feed (1) via throttle (9) and line (6) to the drive cam and from here into the return (5) of the high pressure pump.

An overflow valve (3) is integrated in the high pressure pump. The fuel now released for delivery by the volume control valve flows via the overflow valve into the return of the high pressure pump.

A small quantity of fuel can leak out of the closed volume control valve. To ensure this leakage fuel does not reach the main fuel delivery, it is routed via the zero delivery restrictor (8) into the return flow (5).

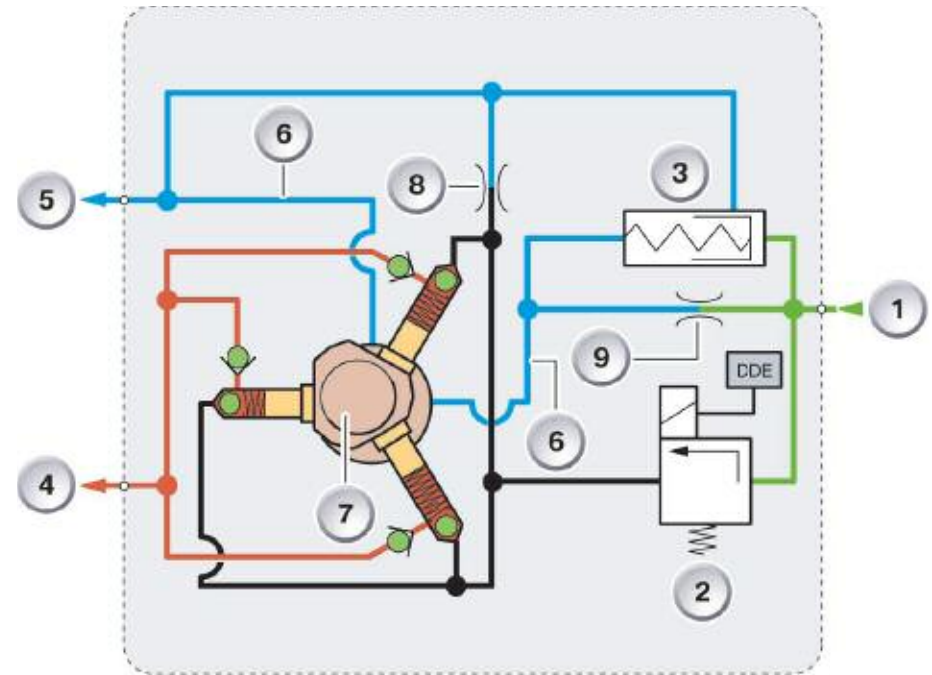

Index	Explanation	Index	Explanation
1	Feed	6	Line for lubricating drive cam and leakage oil return
2	Volume control valve	7	Drive cam
3	Overflow valve	8	Zero delivery restrictor
4	High pressure connection to rail	9	Throttle (restriction) for drive cam lubrication
5	Return		

■ Two-actuator Concept

In the first-generation common-rail system, rail pressure is controlled by a pressure control valve at the high-pressure pump. The CP always delivers fuel at the maximum rate, irrespective of the engine's operating condition. The fuel is heated on account of the high pressure produced by the pump running continuously at its maximum delivery rate. The fuel releases the energy gained in this way in the form of heat in a heat exchanger in the fuel return line.

The two-actuator concept consists of a volumetric fuel control in the line in front of the CP 3.2 and a fuel pressure regulator downline from the pump, at the rail.

Pressure in the rail is controlled by the pressure control valve only during starting and when the coolant temperature is below 19°C. Under these conditions volumetric fuel control is inactive.

In all other operating ranges volumetric fuel control is implemented by the flow regulating valve at the high-pressure pump. Pressure control by the pressure control valve is inactive.

The flow regulating valve on the intake side of the high pressure pump (CP 3.2 plus) is actuated by the DDE control unit. The flow regulating valve controls the pump delivery rate in such a way that only the volume of fuel actually required is supplied to the pump.

The quantity of excess fuel diminishes accordingly, so significantly less heat is generated in the fuel system.

There are many advantages deriving from volumetric fuel control:

- Lower manufacturing costs, because there is no need for a fuel cooler
- Improvements in efficiency and consumption because of the lower power requirement of the common-rail pump
- Optimum combustion and low raw emissions

The two-actuator concept therefore ensures an optimum fuel supply in all operating conditions.

■ Advantages

It can take up to 3-4 kW (4-5 HP) to drive the high pressure pump. This can result in a loss in fuel economy and engine power. By using the two-actuator method of fuel control, the power requirement of the high pressure pump can be reduced in the partial load range of the engine, thus achieving a reduction in fuel consumption of up to 6% depending on the operating point of the engine.

The associated lower heating of the fuel in connection with pressure generation renders the fuel cooler in the engine compartment unnecessary.

Rail Pressure Sensor

The rail pressure sensor is located on the front of the fuel rail. It measures the current pressure in the rail and sends a voltage signal, corresponding to the applied pressure, to the DDE.

The rail pressure sensor and the pressure control valve are adapted to the pressure ranges of the 3rd generation common rail system.



Pressure Control Valve

The pressure control valve is located at the rear of the rail.

The purpose of the pressure control valve is to control the pressure in the rail while starting the engine and when the coolant temperature is below 19°C.

It is actuated by the DDE control unit. The pressure control valve is additionally actuated while coasting to facilitate rapid pressure reduction.



Accumulator (Fuel Rail)

The accumulator (fuel rail) is mounted on the cylinder head and carries the rail-pressure sensor and the pressure control valve. The fuel rail is designed to retain fuel at very high pressure and store the required fuel volume to dampen pressure fluctuations from the high pressure pump.

This arrangement ensures that when the injectors open and close, the rail pressure remains constant. The fuel rail also provides connections for the high pressure lines to the injectors.



High Pressure Fuel Lines

The high pressure fuel lines provide the connection between fuel rail and fuel injectors as well as the connection between the high pressure pump and fuel rail.

The lines must be able to withstand the high pressures and the continuous pressure pulses in the common rail system.

It is essential to avoid over-torquing the lines, a loss of engine power could result from the reduction in fuel flow.



Fuel Injectors

The earlier common rail systems (1st and 2nd generation), used solenoid type fuel injectors. These injectors required as much as 50 volts for operation. Solenoid type injectors do not have the necessary characteristics for the 3rd generation common rail systems.

The third generation common rail system uses piezo-electric injectors. Conventional fuel injectors use an electromagnetic coil to actuate the injector. Piezo type injectors utilize a series of piezo elements to move the internal injector mechanism.

The piezo-technology offers the following advantages:

- Nozzle needle movement twice as fast
- Switching times 5 times faster with very short dead time
- More effective metering of multiple injection
- High lift accuracy
- Lower hydraulic and electrical power requirements
- Compact design
- Moved mass reduced by 75%
- Weight reduced by 33%
- Possible to increase rail pressure to 1800 bar.

These advantages are reflected in distinct improvements regarding pollutant emissions, fuel consumption and acoustics.



Index	Explanation
1	Control chamber
2	Piezo element
3	Hydraulic return
4	Hydraulic inlet
5	Actuator module
6	Coupler module
7	Shift valve
8	Nozzle needle

Piezo-Electric Principles

Up until now, the most familiar application of piezo technology in automobiles has been the knock sensor. The knock sensor (KS) consists of piezo electric crystals which generate a voltage when a force is exerted. When an engine knock occurs, the resulting vibration acts upon the piezo crystals in the knock sensor. A voltage is generated and sent to the engine management to indicate the presence of engine knock.

Taking what is known about knock sensors, the piezo injector uses the “inverse” method. When a voltage is applied to the piezo crystal, the crystal expands by a specified amount. By stacking the piezo elements, the required amount of movement can be obtained.

The new fuel injector design uses a piezo-ceramic elements and an electro-mechanical converter. This “inverse piezoelectric effect” is now used to convert electrical signals into mechanical movement.

Piezo Technology

Some of the first discoveries in piezoelectric technology were as early as the 1880's. Among the early pioneers in this area was Pierre and Jacques Curie. It was discovered that certain naturally occurring crystals (such as quartz and topaz) exhibited surface charges when subjected to external forces.

Since then, there have been numerous advances in this area. Modern day applications of piezoelectric technology include microphones and phonographic needles. Various automotive applications include knock sensors, pressure sensors and acceleration sensors.

Today, many present day sensors include man-made piezo electric materials such as piezo-ceramic and piezo-resistive materials. Most modern day vehicles utilize a variety of piezo-electric devices in one or more vehicle systems.

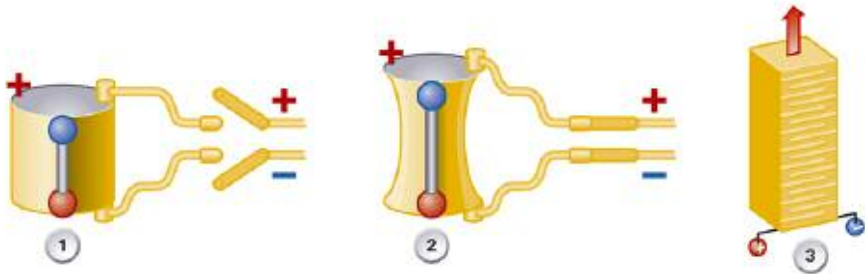

Index	Explanation
1	Piezo element with no voltage applied
2	Piezo element with no voltage applied
3	Piezo element (layers) with voltage applied

Fuel Injector Operation

Circuited between the two elements is the coupler module, which functions as a hydraulic compensating element, e.g. to compensate for temperature-related length expansions.

When the injector is controlled, the actuator module expands. This movement is transferred to the switch valve by the coupler module. When the switch valve opens, the pressure in the control chamber drops and the nozzle needle opens in exactly the same way as with the solenoid valve injector.

The benefits of the PIEZO injector are that they offer a considerably faster control response, which results in greater metering accuracy.

In addition, the PIEZO injector is smaller, lighter and has a lower power consumption. The M57D30T2 engine is equipped with PIEZO injectors that have been developed further still and are even more compact and lighter.

■ Leakage Oil

A certain amount of leakage oil occurs in the injectors due to the design of the system. On the one hand, this is fuel that flows away as a control volume when the switch valve or outlet restrictor opens. On the other hand, a certain amount of fuel is always forced past the switch valve or outlet restrictor as a result of the pressure in the injector.

This volume flows into the leakage oil line that is connected to each injector. At this point, the systems in the upper and lower power class differ.

In the lower power class, this leakage oil is directed into the return line back to the fuel tank.

In the upper power class, the leakage oil is directed into the supply line to the high pressure pump. The reason for this is that the switch valve in the PIEZO injector needs a certain back pressure to work correctly.



Low Pressure System

As with current gasoline fuel injection systems, there is an electric fuel pump located in the fuel tank. The fuel pump supplies the needed low pressure fuel to feed the mechanical high-pressure pump.

As with BMW gasoline engines, the fuel system on the vehicles equipped with diesel engines share much of the same “low pressure” system components.

The fuel tank is equipped with two chambers and, on modern vehicles, is usually made from plastic.

The electric fuel pump on the diesel engines is driven by the EKP module. The fuel supply system has two delivery units that are accommodated in the right and left fuel tank halves.

The fuel pump (14) with pre-filter (11) is a part of the right-hand delivery unit. The swirl pot including a suction jet pump (10), a non-return valve and initial filling valve (12) as well as a fuel level sensor (9) complete this delivery unit. The fuel pump and swirl pot can only be replaced together.

The suction jet pump (18), fuel level sensor (20) and two non-return valves (19 + 21) belong to the left-hand delivery unit.

A line leads from the refuelling vent valve (28) to the fuel filler neck. The fuel supply system features two delivery units that are located in each of the two tank halves.

■ Function

The electric fuel pump (14) with intake screen (11) pumps the fuel via the right-hand delivery unit into the fuel filter (23) outside the fuel tank.

The electric fuel pump is driven by the EKP module (7) with a pulse width-modulated signal. The EKP module receives the PWM instruction from the digital diesel electronics (DDE) (29).

The DDE now uses the measured values of a near-engine pressure/temperature sensor (1) for the purpose of calculating the PWM instruction. The EKP is also pressure controlled depending on the pressure upstream of the high-pressure pump (2).

In this way, the electric fuel pump is activated as required thus saving fuel. The fuel filter (23) is heated and is connected to the DDE in the standard way by means of a diagnosis cable of the filter heater system.

The high-pressure pump (2) produces the required pressure in the common rail system. Surplus fuel that is given off at the volume control valve in the high-pressure pump (2) and at the pressure control valve (5) is routed via a return line back into the fuel tank while the leakage oil (fuel) of the fuel injectors (6) flows back into the supply line to the engine (25).

The fuel return (24) to the fuel tank is used to operate two suction jet pumps (10, 18). The non-return valve (21) prevents the fuel return running empty and maintains a pressure of 30 mbar during operation to prevent bubbles forming in the return lines.

The suction jet pump (18) on the left delivers fuel from the left-hand tank half to the swirl pot. The suction jet pump on the right fills the swirl pot from the right-hand tank half.

At high fuel return rates, a pressure relief valve (8) ensures that excessively high pressure does not occur in the return line in that it opens at a pressure of 0.55 bar and allows the fuel to drain directly into the swirl pot.

The drain-off control valve (19) prevents the swirl pot draining off into the left-hand tank half when the vehicle is parked at an incline. The valve opens when there is no pressure in the return line (16) allowing air to enter the line. The lines drain off so as to prevent the so called siphon effect.

Fuel Supply System Overview

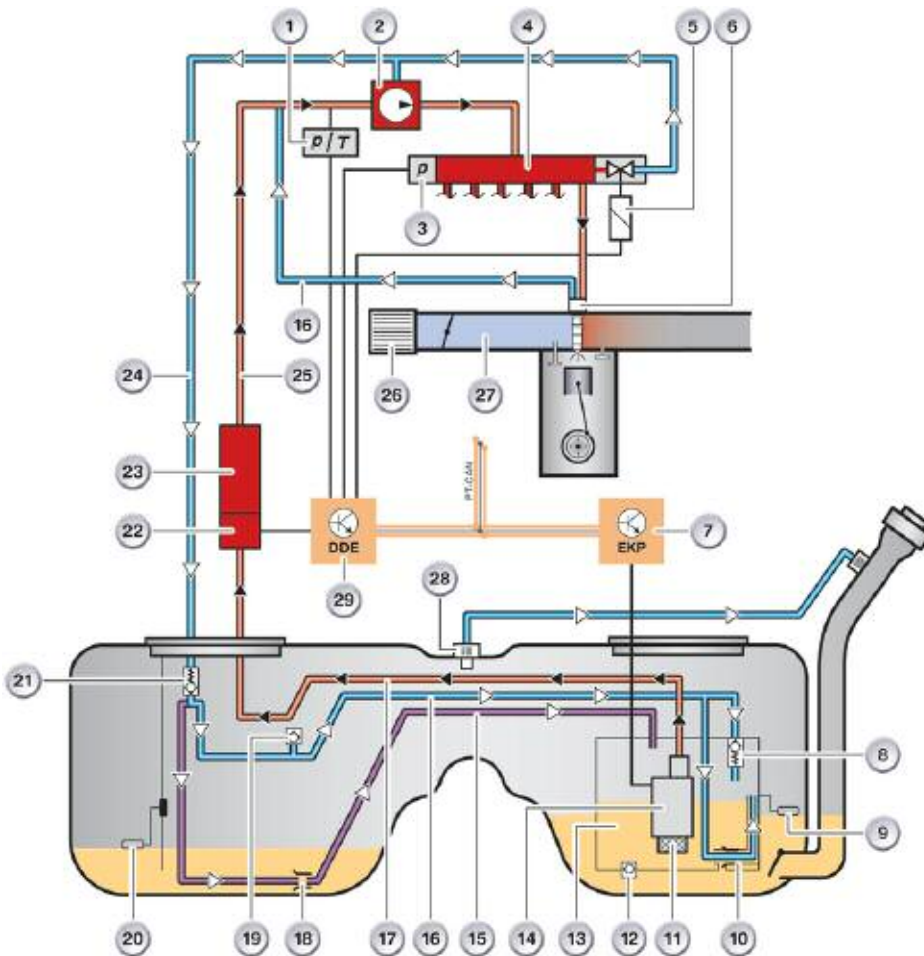

Typical fuel system from E70 with diesel engine

Index	Explanation	Index	Explanation
1	Pressure/temperature sensor	16	Return line
2	High pressure fuel pump	17	Feed line
3	Rail pressure sensor	18	Suction jet pump
4	Fuel rail (accumulator)	19	Drain off control valve
5	Pressure control valve	20	Fuel level sensor
6	Fuel injector	21	Non-return valve
7	EKP module	22	Fuel heater
8	Pressure relief valve	23	Fuel filter
9	Fuel level sensor	24	Return flow line from engine
10	Suction jet pump	25	Feed line to engine
11	Intake mesh filter	26	Engine air cleaner
12	Initial filling valve	27	Intake manifold
13	Swirl pot	28	Refuelling vent valve
14	Electric fuel pump	29	Digital Diesel Electronics (DDE)
15	Compensating line		

A line branches from the return (24) for the purpose of feeding the suction jet pump (18) in the left-hand tank half. This pump conveys fuel from the left-hand tank half via the compensation line (15) into the swirl pot. A non-return valve (21) from the suction jet pump (10) prevents the right-hand fuel tank emptying via the return line (16) when the vehicle is parked on a slope.

In the event of the swirl pot being completely empty, the initial filling valve (12) ensures fuel enters the swirl pot while refuelling.

EKP Control Module

The fuel pump is controlled by the DDE via the EKP module. The EKP module operates in much the same way as the gasoline version does. As in the past, the EKP module stores the fuel mapping requirements through vehicle specific encoding.

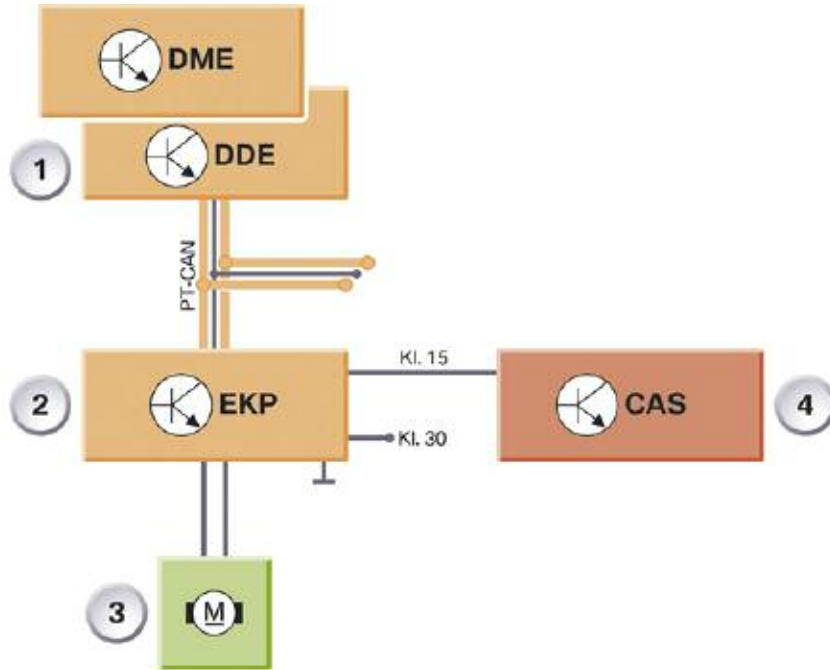

Index	Explanation
1	DDE Control Module
2	EKP Module
3	Fuel Pump
4	Car Access System

The EKP control module uses the mappings as the basis on which to calculate the total amount of fuel to be delivered from the following reference variables:

- Amount of fuel required by the engine (as a request from the DDE control unit)
- Amount of fuel needed to lubricate the high-pressure pump in the diesel fuel system (mapping in the EKP control unit).

This results in a pulse-width modulated output voltage from the EKP control module. The output voltage of the EKP control module is the supply voltage for the electric fuel pump. The EKP control module controls the speed of the electric fuel pump via the supply voltage. The speed of the fuel pump is compared to the actual specification stored in the EKP control module controls the speed by comparing the actual speed with the specification.

The current speed of the electric fuel pump is calculated as follows:

The EKP control unit sends the current supply to the fuel pump (pulse-width modulated). This voltage is absorbed as a specific ripple due to the individual armature windings of the rotating electric motor. The ripple corresponds with the number of segments in the commutator (= corresponds with the number of armature windings in the electric motor).

The number of waves produced per revolution is equal to the number of existing commutator segments.

This means that the EKP control unit can employ a patented procedure (= "Ripple Counter") as the basis for calculating the actual speed of the fuel pump using power consumption ripple.

Fuel Filter Heater

The electric filter heater prevents paraffin separation in the diesel fuel in winter. The fuel filter with electric heater is secured in a crash-safe arrangement in the underbody.

The filter heater is inserted in the fuel filter housing and secured with a clip to prevent it falling out. Simple replacement of the fuel filter is therefore possible.

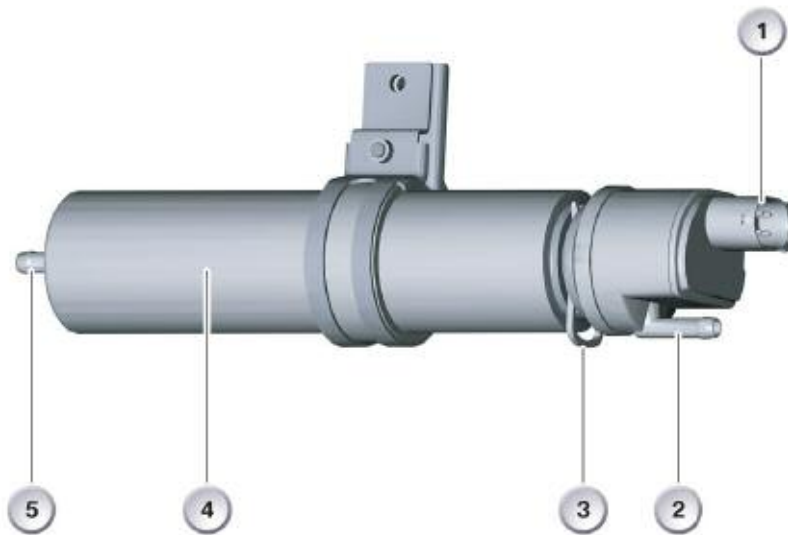

Index	Explanation
1	Electrical connection
2	Low pressure fuel inlet
3	Retaining clip
4	Fuel filter housing
5	Fuel outlet

Functional Principle

The fuel flows through the electric filter heater (380 W) into the filter element.

The electric filter heater features an electronic control circuit with a pressure switch and a temperature sensor. The pressure switch and temperature sensor are positioned at the inlet to the fuel filter.

The electric filter heater switches on under the following conditions depending on the fuel pressure and fuel temperature:

- On exceeding a certain fuel pressure (in filter inlet) by cold, viscous fuel.
- On exceeding a certain temperature value (below 2°C) of the diesel fuel.

The electric heating element is powered via terminals 30. The heating element is activated (terminal 31) on the ground side directly by the integrated electronic control circuit. Voltage is supplied to the electronic control via terminal 15.

The filter heater is normally not switched on during operation with winter diesel.



Classroom Exercise - Review Questions

1. On the common rail system, the pressure control valve is used to control the fuel pressure when:

Select the BEST possible answer

- A. When the coolant temperature is above 19 degrees Celsius and while decelerating
- B. When the coolant temperature is below 19 degrees Celsius and while starting
- C. When the engine is at WOT (VL)
- D. When the engine is at idle only

2. The M57D30T2 engine uses DDE version:

Select the BEST possible answer

- A. 2X
- B. 4X
- C. 6X
- D. 7X

3. Which of the following types of actuator is used to control the EGR valve?

Select the BEST possible answer

- A. EPDW
- B. EUV
- C. KWG
- D. NWG

4. M21 engine used the _____ method of injection.

Select the BEST possible answer

- A. Swirl chamber
- B. Pre-chamber
- C. Direct Injection
- D. Common Rail

5. The High Pressure Pump is driven by the:

Select the BEST possible answer

- A. Timing Chain
- B. Exhaust camshaft
- C. Intake camshaft
- D. Vacuum pump



Classroom Exercise - Review Questions

6. The Volume control valve is located:
Select the BEST possible answer
- A. On the fuel rail
 - B. On the high pressure pump
 - C. In the fuel tank
 - D. On the low pressure fuel line
 - E. Behind the right front fender
7. The “two-actuator” concept refers to which two actuators?
Select the BEST possible answer
- A. Pressure control valve and EKP module
 - B. Pressure control valve and volume control valve
 - C. Volume control valve and EUV
 - D. Volume control valve and Piezo injectors
8. Cross out the components which would not be found in the fuel tank on the diesel fuel supply system?
- A. Siphon jet
 - B. Fuel filter
 - C. Fuel pressure regulator
 - D. Electric fuel pump
 - E. Refuelling vent valve
9. Which of the following actuators is not found on the BMW diesel engine management systems (DDE)?
Select the BEST possible answer
- A. Purge valve
 - B. E-box fan
 - C. Volume control valve
 - D. Pressure control valve
 - E. EUV
10. Which of the following BEST describes the high pressure fuel pump (CP3.2)?
Select the BEST possible answer
- A. A 2-piston inline pump
 - B. A vane type pump
 - C. A 3-piston radial pump
 - D. A 4-piston inline pump

Diesel Air Management

Air Intake System

In addition to reducing the intake noise, the air intake system ensures an optimum supply of fresh air to the combustion chamber. A wave of negative pressure acting against the direction of flow of the fresh air intake is created by the movement of the piston after opening the intake valve.

The resulting pressure fluctuations are radiated in the form of sound via the mouth of the intake system. In addition, the pulsation that occurs inside the air intake system causes the walls of the components to vibrate, thus also radiating noise. The air intake system is therefore optimized in such a way that no disturbing or annoying vibration can occur thus conforming to the noise emission limits applicable worldwide.

The intake system can be divided into two sections. The intake snorkel, intercooler and, with exceptions, the intake silencer are specifically assigned to the vehicle and differ even in connection with the same type of engine due to the different characteristics of the vehicle models.

The exhaust turbocharger and the intake system with swirl flaps, throttle valve and various sensors are assigned to the engine.

Apart from the exhaust turbocharger and exhaust manifold, the exhaust system is designed vehicle-specific and differs depending on the type of vehicle and specification.

The unfiltered air (A) that is drawn in reaches intake silencer (2) through the intake snorkel (not shown) and unfiltered air pipe (1). In the intake silencer, the unfiltered air is filtered to become filtered air (B). The filtered air flows via hot-film air mass meter (3) and filtered air pipe (4) to exhaust turbocharger (5).

At the same time, blow-by gases are fed into the filtered air pipe through blow-by gas connection (11). In the exhaust turbocharger, the filtered air is compressed and thereby heated.

The compressed, heated charge air (C) is conveyed in charge air pipe (6) to intercooler (7). From the intercooler, the now cooled charge air (D) flows via charge air pipe (8) past charge air temperature sensor to throttle valve (9). Depending on the position of the throttle valve more or less cooled charge air (D) flows into intake manifold (10).

The inlet for the recirculated exhaust gas also joins the intake manifold.

Note: If the filtered air pipe downstream of the blow-by gas connection is heavily oiled, this could imply increased blow-by gas levels. The cause of this is usually a leak in the engine (e.g. crankshaft seal) or surplus air taken in through the vacuum lines.

A consequential symptom would then be an oily exhaust turbocharger, which does not mean that there is a fault with the exhaust turbocharger itself.

Air Intake System Overview

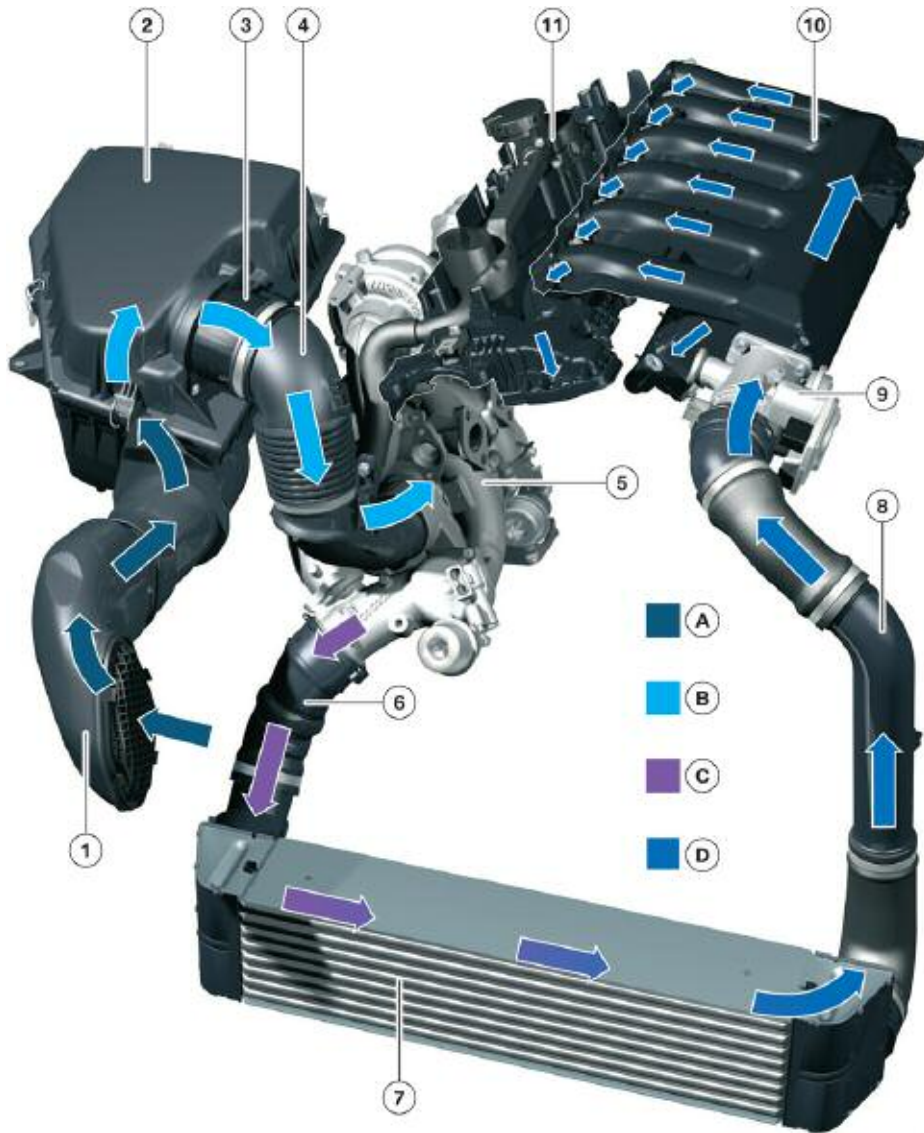

Index	Explanation
A	Unfiltered air
B	Filtered air
C	Heated charge air
D	Cooled charge air
1	Unfiltered air snorkel
2	Intake air silencer
3	Hot-film air mass meter
4	Filtered air pipe
5	Exhaust turbocharger
6	Charge-air pipe
7	Intercooler
8	Charge-air pipe
9	Throttle assembly
10	Intake air manifold
11	Valve cover with swirl ports

Intake Silencer/Air Filter

The intake silencer houses the filter element and is designed such that the filter element has as long a service life as possible. The larger the filter element, the longer the service life and also the greater the space requirement.

The housing of the intake silencer is also designed to deform in the event of impact from above (pedestrian collision). This means that it compresses by several centimeters.

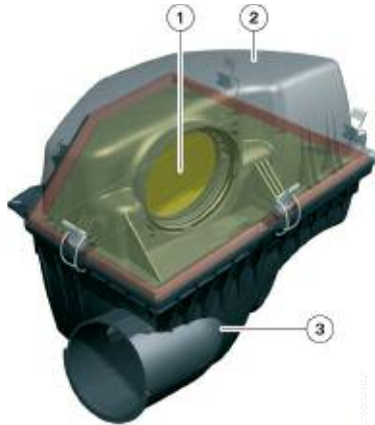

Index	Explanation
1	Filter element
2	Housing
3	Intake Silencer

M57D30T2 Engine

Due to space restrictions on twin turbo engines, the intake silencer is not fitted directly on the engine. In this case, the intake silencer is positioned laterally on the wheel well.

The intake silencer reduces the intake noise and houses the filter element.

Unfiltered Air Duct

The unfiltered air duct consists of the unfiltered air snorkel, pipe and the unfiltered air area of the intake silencer. The unfiltered air snorkel and pipe are designed with the crash safety of pedestrians in mind. This entails the use of especially soft materials and yielding connections.



Index	Explanation
1	Coarse mesh screen
2	Unfiltered air snorkel
3	Unfiltered air pipe
4	Unfiltered area of intake snorkel
5	Filter element
6	Filtered area of intake snorkel

The M57D30T2 engine draws in the unfiltered air laterally behind the bumper ahead of the cooling module. The unfiltered air is routed via coarse-mesh screen (1) via unfiltered air snorkel (2) and unfiltered air pipe (3) into the unfiltered air area of intake silencer (4).

The coarse-mesh screen prevents large particles such as leaves from being drawn in. The unfiltered air snorkel in the M57 engine is designed as an unfiltered air intake shroud. This has a large surface area, but is exceptionally flat. The air is drawn in by the cooling module.

Intercooler

The temperature of the air increases as the air is compressed in the exhaust turbocharger. This causes the air to expand. This effect undermines the benefits of the exhaust turbocharger because less oxygen can be delivered to the combustion chamber.

The intercooler cools the compressed air, the air's density increases and thus more oxygen can be delivered to the combustion chamber.

On BMW diesel engines, charge air is cooled exclusively by fresh air with an air-to-air heat exchanger. The charge air cooling rate greatly depends on the vehicle speed, temperature of the incoming fresh air and the design of the intercooler.

The main purpose of turbocharging in a diesel engine is to boost output. Since more air is delivered to the combustion chamber as a consequence of "forced aspiration", it is also possible to have more fuel injected, which leads to high output yields.

However, the air density and therefore the mass of oxygen that can be delivered to the combustion chamber is reduced because the air heats up, and thus expands, as it is compressed.

The intercooler counteracts this effect because the cooling process increases the density of the compressed air, i.e. so too the oxygen content per volume.

As a result, a larger volume of fuel-air mixture can be combusted and converted into mechanical energy. The intercooler is responsible for reduced intake air temperatures compared to a vehicle with no intercooler. This means the power output can be additionally increased as a larger mass of air can be conveyed into the combustion chamber.

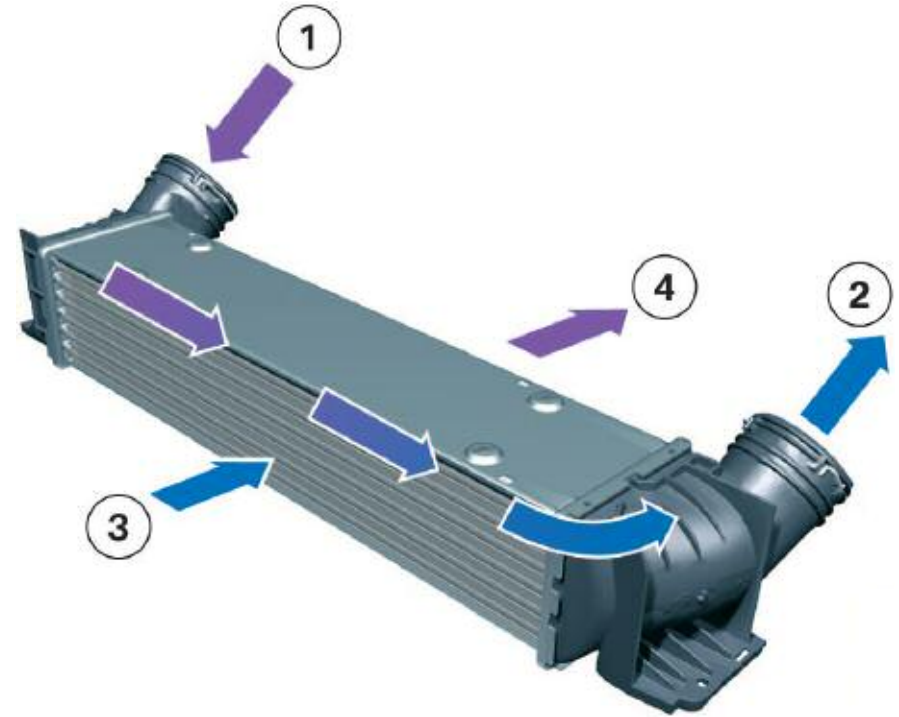

Index	Explanation
1	Heated charge air
2	Cooled charge air
3	Cooled fresh air
4	Heated fresh air

Throttle Valve

A throttle valve is required in all diesel engines, including those equipped with a diesel particulate filter. By throttling the intake air, the throttle valve ensures that the elevated exhaust gas temperatures required for diesel particulate filter regeneration are achieved.

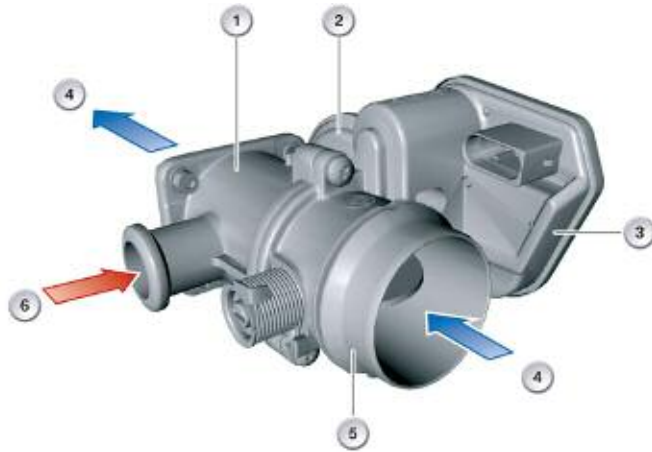

Index	Explanation
1	Throttle housing
2	EGR vacuum diaphragm
3	Throttle motor with feedback electronics
4	Incoming air
5	Charge air hose connection from intercooler
6	EGR connection

The throttle valve is closed when the engine is shut down to avoid engine shudder. After the engine has stopped, the throttle valve is reopened.

The throttle valve also serves the additional function of effectively preventing over-revving of the engine. If the DDE detects over-revving without an increase in the injection volume, the throttle valve will close in order to limit the engine speed.

This situation can occur as the result of combustible substances entering the combustion chamber. Substances may be engine oil from an exhaust turbocharger with bearing damage. This function can effectively prevent major damage to the engine. The throttle valve is located directly upstream of the intake manifold.

The DDE calculates the position of the throttle valve from the position of the accelerator pedal and from the torque requirement of other control units. The DDE controls actuation of the throttle valve by means of a PWM signal with a pulse duty factor of 5 to 95%.

To achieve optimum control of the throttle valve, its exact position must be recorded on a continual basis. The throttle valve position is monitored contactlessly in the throttle valve actuator by 2 Hall sensors. The sensors are supplied with a 5 V voltage and connected to ground by the DDE. Two data lines guarantee redundant feedback of the throttle valve position to the DDE.

The second signal is output as the inverse of the first. The DDE evaluates the plausibility of the signal through subtraction.

The actuator motor for operating the throttle valve is designed as a DC motor. It is driven by the DDE on demand. An H-bridge is used for activation which makes it possible to drive the motor in the opposite direction. The H-bridge in the DDE is monitored by the diagnostics system.

When no power is applied to the drive unit, the throttle valve is set, spring-loaded, to an emergency operation position.

The throttle valve is required for regenerating the diesel particulate filter in order to increase the exhaust temperature by intervening in the air-fuel mixture. In addition, the throttle valve is closed when the engine is shut down in order to reduce shut-down shudder.

The throttle valve also effectively prevents over-revving of the engine.

Swirl Flaps

Swirl flaps ensure better swirl of the incoming air during the intake and compression cycles. This method of air control works in conjunction with the piston geometry to ensure more complete mixture formation.

By controlling “swirl” within the combustion chamber, significant reductions in NOx and particulate emissions are possible.

The adjustable swirl flaps are located in the tangential channels of the intake system and are opened and closed according to the operating status of the engine.

On the M57TU engine, the swirl flaps are closed at low RPM and load conditions. This is a map-controlled function. To increase the swirl effect, swirl flaps are designed to close tightly on the M57TU engines.

Swirl Flap Operation

Swirl flap (4) closes tangential port (3) to achieve greater turbulence of the air via swirl port (2) in the combustion chamber at low engine speeds. With increasing engine speed, it opens to facilitate charging through the tangential ports.

The position is based on the driver's load choice, engine speed and the coolant temperature.

The swirl flaps are varied by a linkage (1) that is operated by a DC motor or a vacuum unit (3).

The pressure converter connects the vacuum unit with the vacuum supply by means of hoses. When activated by the DDE control module, the changeover valve switches vacuum to the vacuum unit. The vacuum unit actuates the control rod and the swirl flaps close. The control rod is up against the rear stop when the swirl flaps are open.

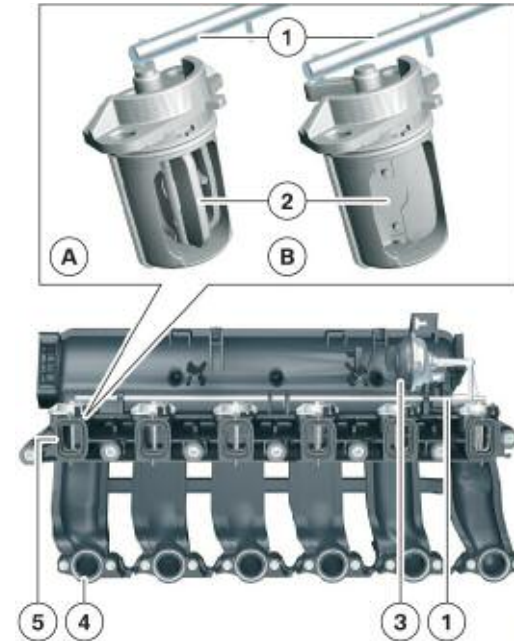

Index	Explanation
A	Swirl Flaps - Open
B	Swirl Flaps - Closed
1	Linkage
2	Swirl Flap
3	Vacuum Diaphragm
4	Swirl Port
5	Tangential port

■ Effects of Swirl Flap Malfunctions

If the swirl flaps stick in open position: Deterioration in exhaust gas characteristics in lower speed ranges otherwise no effect.

If the swirl flaps stick in closed position: Power loss of approximately 10% at higher engine speeds.

Hot-film Air Mass Meter (HFM 6.4)

The hot-film air mass meter HFM 6.4 is used together with DDE on the M57TU. The HFM 6.4 is designed for an air throughput rate of up to 640 kg air/h.

The HFM 6.4 measures the air mass intake within very close tolerances so as to permit precise control of the exhaust gas recirculation as well as optimum configuration of the smoke limit. This is important for complying with current and future emission limits.

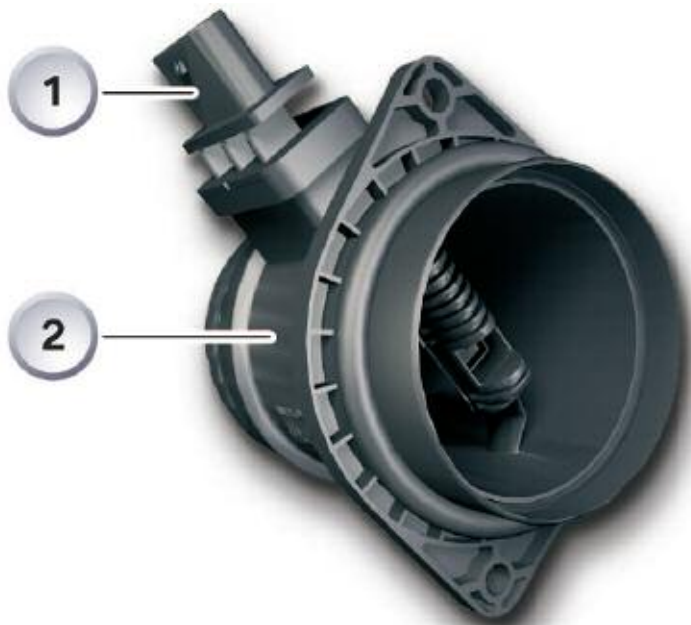

■ Functional Principle

The principle design of the HFM 6.4 corresponds to that of the HFM 5 previously used. The hot-film air mass meter HFM 6.4 is powered with system voltage.

A new feature is that the sensor signal is digitized already in the HFM 6.4. The digitized signal is transferred frequency-modulated to the DDE.

In order to be able to compensate for the temperature influences, the air mass signal is referred to the changing temperature signal.

The HFM 6 hot-film air mass meter is located downstream of the intake silencer and is fitted directly to its cover. The HFM measures the air mass taken in by the engine. This is used to record the actual air mass, which in turn is used to calculate the exhaust gas recirculation rate and the fuel limit volume.

There is also an intake air temperature sensor located in the HFM housing. The temperature is evaluated by the HFM and sent to the DDE as a PWM signal.

A pulse width of 22% equates to a temperature of -20°C and a pulse width of 63% equates to a temperature of 80°C .

■ Measurement Method

A labyrinth (6) makes sure that only the actual air mass is recorded. Thanks to the labyrinth, backflow and pulsation are not registered. In this way, the HFM determines the actual air mass irrespective of the air pressure and backflow.

An electrically heated sensor measuring cell (7) protrudes into the air flow (4). The sensor measuring cell is always kept at a constant temperature. The air flow absorbs air from the measuring cell. The greater the mass air flow, the more energy is required to keep the temperature of the measuring cell constant.

The evaluator electronics (3) digitizes the sensor signals. This digitized sensor signal is then transferred frequency-modulated to the DDE. In order to be able to compensate for temperature influences, the air mass signal is referred to the variable temperature signal.

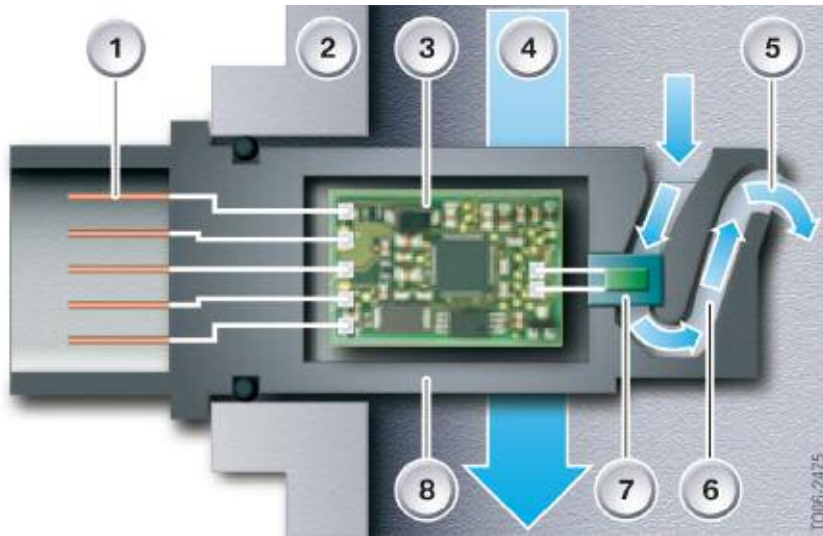

Index	Explanation
1	Electric connections
2	Measurement tube housing
3	Electronic evaluator
4	Mass air flow
5	Partial flow for measurement, exhaust
6	Labyrinth
7	Sensor measuring cell
8	Sensor housing



Index	Explanation
A	Air mass signal
B	Air mass
C	Temperature signal
1	Air mass signal (A) as a function of air mass (B) and temperature signal (C)
2	The period duration of the air mass signal (A) decreases as the air mass (B) increases
3	The period duration of the air mass signal (A) is extended as the air mass (B) reduces
4	When the temperature increases (C) and air mass (B) remains constant, the period duration of the air mass signal (A) is extended in order to compensate for temperature influences
5	When air mass (B) increases, the period duration of the air mass signal decreases while taking the temperature signal (C) into account

Charge Air Temperature Sensor

The charge-air temperature sensor records the temperature of the compressed fresh air. It is located in the boost-pressure pipe, directly upstream of the throttle valve.

The charge-air temperature is used as a substitute value for calculating the air mass. This is used to check the plausibility of the value of the HFM. If the HFM fails, the substitute value is used to calculate the fuel flow measurement and the EGR rate.



The DDE connects the intake temperature sensor to ground. A further connection is connected to a voltage divider circuit in the DDE.

The intake temperature sensor contains a temperature-dependent resistor that protrudes into the flow of intake air and assumes the temperature of the intake air.

The resistor has a negative temperature coefficient (NTC). This means that the resistance decreases as temperature increases.

The resistor is part of a voltage divider circuit that receives a 5 V voltage from the DDE. The electrical voltage at the resistor is dependent on the air temperature. There is a table stored in the DDE that specifies the corresponding temperature for each voltage value; the table is therefore a solution to compensate for the non-linear relationship between voltage and temperature.

The resistance changes in relation to temperature from about 75 k Ohms to 87 Ohms, corresponding to a temperature of -40°C to 120°C .

Boost Pressure Sensor

The boost pressure sensor is required for boost pressure control. The boost pressure sensor monitors and controls the boost pressure in accordance with a characteristic map resident in the DDE.

The boost pressure is also used for calculating the volume of fuel. The sensor is supplied with a 5 V voltage and connected to ground by the DDE. The information is sent to the DDE on a signal line.

The evaluation signal fluctuates depending on the pressure. On the M57D30T2 engine, the measuring range from approximately 0.1 - 0.74 V corresponds to an absolute pressure from 50 kPa (0.5 bar) to 330 kPa (3.3 bar).



Vacuum System

On the diesel engine, numerous Vacuum operated devices are used to control EGR, turbocharging and motor mounts.

To simplify assignment, the vacuum lines from several valves to the vacuum units are marked in color. This color code is also used for the actual components.

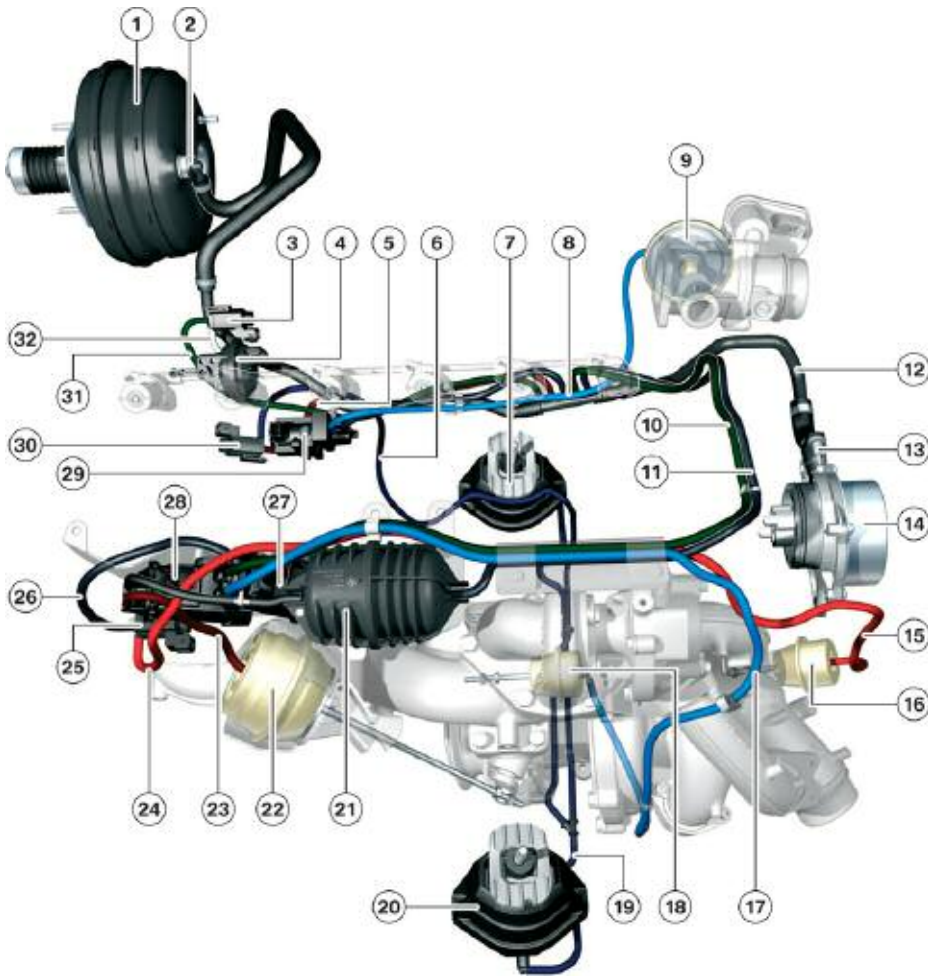

Index	Explanation	Index	Explanation
1	Brake booster	17	Vacuum line, EPDW wastegate
2	Non-Return valve	18	Vacuum unit for wastegate
3	EUV Swirl flaps	19	Vacuum line, EUV engine mount
4	Vacuum unit for swirl flaps	20	Engine mount
5	Vacuum line, EUV engine mount	21	Vacuum reservoir
6	Vacuum line, engine mount	22	Vacuum unit, EPDW turbine control valve
7	Variable engine mount	23	Vacuum line, EPDW turbine control valve
8	Vacuum Distributor	24	Vacuum line, EUV compressor bypass valve
9	Vacuum unit for EGR valve	25	EUV compressor bypass valve
10	Vacuum line, EDPW wastegate	26	Vacuum line, EUV compressor bypass valve
11	Vacuum line, Vacuum reservoir	27	EPDW wastegate
12	Vacuum line brake booster	28	EPDW turbine control valve
13	Non-Return valve	29	EPDW EGR valve
14	Vacuum pump	30	EUV engine mount
15	Vacuum line, EUV compressor bypass valve	31	Vacuum line swirl flaps
16	Vacuum unit for compressor bypass valve	32	Vacuum line, EUV swirl flaps

Component	Color
Wastegate	Blue
Compressor bypass valve	Red
Turbine control valve	Black
EGR Valve	Blue
Engine mount	Black
Swirl flaps	White

Vacuum Pump

The vacuum pump is driven by the exhaust camshaft that is connected to rotor (3) by means of a jaw clutch. While the engine is running, sliding blocks (1) run against housing cover (4).

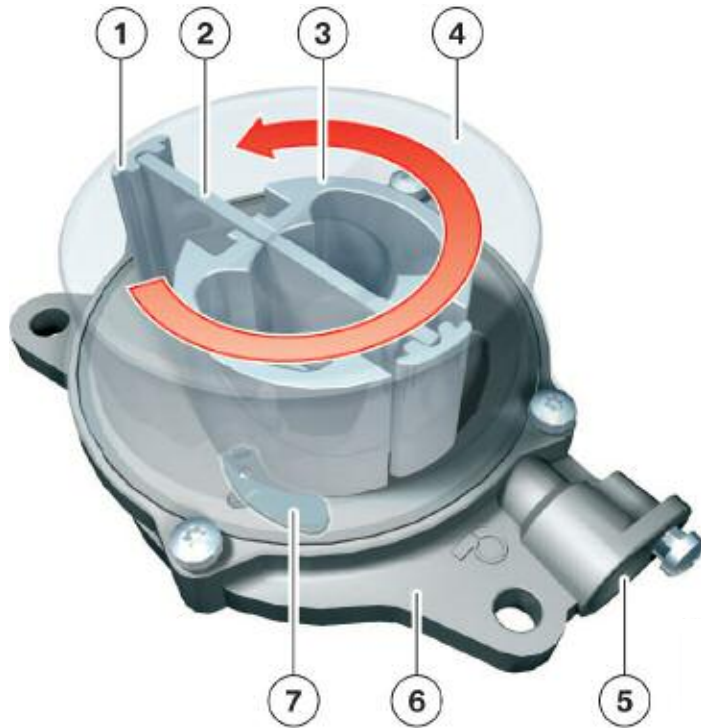

Index	Explanation
1	Sliding block
2	Slide valve
3	Rotor
4	Housing cover
5	Vacuum connection
6	Housing
7	Non-return valve

The engine oil lubrication system provides a seal to the two different chambers on both sides of slide valve (2). The air is drawn in via vacuum connection (5) on the right-hand side and delivered to the engine via non-return valve (7) on the left-hand side.

The vacuum pump has a volume of 0.15 liters. Evacuation of the vacuum system to a vacuum (negative pressure) of 500 mbar (absolute) (depending on type of engine) takes place in less than 5 seconds at an engine speed of approximately 720 rpm.

The volume to be evacuated amounts to approximately 4.2 liters.

Vacuum pump



Non-return Valve

The non-return valve prevents vacuum escaping via the vacuum pump when the engine is not running.

Retaining ring (1) supports spring (6). The other end of the spring presses seal (5) against hole (3). The vacuum built up in the hole and in the vacuum system firmly sucks the seal onto the hole, ensuring no vacuum can escape via the vacuum pump. The seal is forced against the spring while the vacuum pump is in operation thus releasing the hole.

Air can now be drawn in via the hole and openings (2) in the seal.

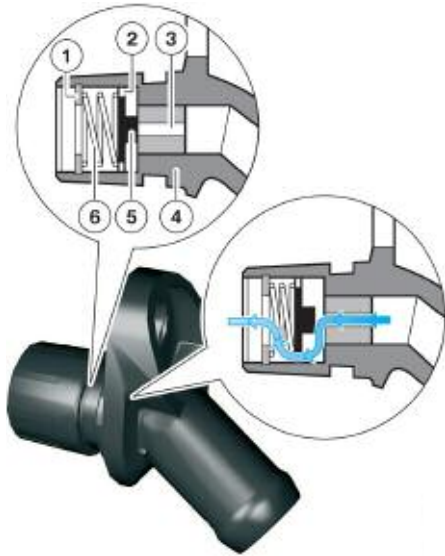

Index	Explanation
1	Retaining ring
2	Opening
3	Hole
4	Housing
5	Seal
6	Spring

Non-return Valve, Brake Booster

The non-return valve prevents vacuum escaping from the brake booster when the engine is not running.

From the vacuum connection to vacuum pump (2), the air is drawn out of the brake booster via valve plate (1) above the brake booster vacuum connection. To prevent incorrect installation, direction arrows (3) indicate the direction of flow (4).

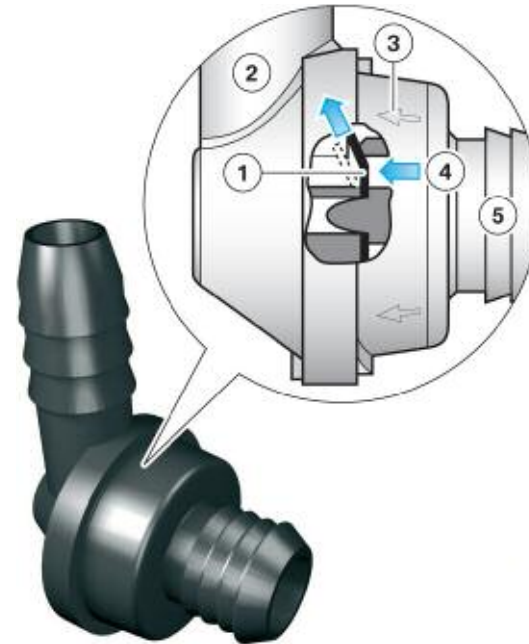

Index	Explanation
1	Valve plate
2	Vacuum connection to vacuum pump
3	Direction arrow
4	Direction of flow
5	Vacuum connection, brake booster

Vacuum Distributor

The task of the vacuum distributor is to distribute the vacuum via lines to various system. Different sized apertures (orifice) are built into the connections of the vacuum distributor.

This makes sure that the majority of the vacuum is always available for power assisted braking. Unused connections are closed off with a rubber cap.

A distributor with five connections is used on the M57D30T2 engine.

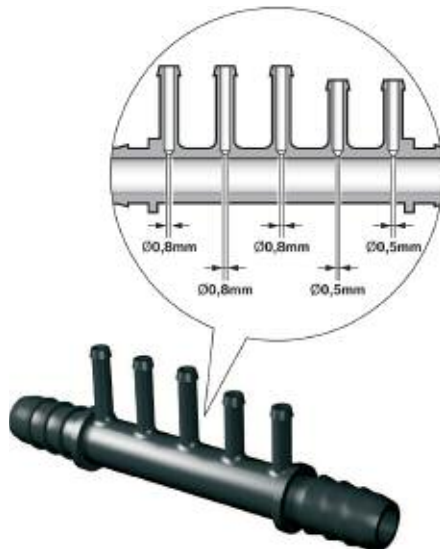

Connection	Orifice Size
Wastegate	0.8 mm
Compressor bypass/Turbine control valve	0.8 mm
EGR Valve	0.8 mm
Engine mount	0.5 mm
Swirl flaps	0.5 mm

Vacuum Reservoir

The vacuum reservoir retains a defined vacuum for the purpose of making available vacuum to meet temporary increases in vacuum requirements.

For instance, on twin turbo engines this makes it possible to still control the turbine control valve and the compressor bypass valve in the event of the vacuum failing in the system. If this would not be possible, an immediate drop in engine output would be noticeable.

A situation in which such a failure in the vacuum system may occur is when the brake booster requires large quantities of vacuum.

For this purpose, the vacuum reservoir is equipped with a non-return valve that prevents the vacuum escaping in the direction of the brake booster.

If it were not for this vacuum reservoir, the vacuum pump would have to be built much larger so as to make available sufficient vacuum to control the turbocharger assembly while the brake booster is operating at maximum.

However, the capacity of such a pump would be fully utilized only very rarely. A vacuum reservoir therefore represents the most efficient option of covering maximum vacuum requirements.

Electro-pneumatic Pressure Converter (EPDW)

The Electro-pneumatic pressure converter is used for components that are activated infinitely variable with vacuum. The Electro-pneumatic pressure converter is able to mix the incoming vacuum with ambient air and set any required negative pressure (mixed pressure) between these two negative pressure levels.

The resulting negative pressure is then used as the control variable for actuating pneumatic components.

These components include:

- Vacuum unit for EGR valve
- Vacuum unit for turbine control valve
- Vacuum unit for wastegate

The vacuum (negative pressure) is applied at vacuum connection (1). The ambient pressure passes through filter element (3) into the valve. Vacuum connection outlet (2) may be marked in color (here blue) to prevent confusion with several components of the same type.

The mixed pressure is made available via the vacuum outlet. The mixed pressure is used to set infinitely variable any position between "open" and "closed".

The DDE actuates the Electro-pneumatic pressure converter pulse width modulated at approximately 300 Hz. The negative pressure at the vacuum outlet is infinitely variable depending on the pulse duty factor.

The pulse duty factor may be between 0 and 100%. The Electro-pneumatic pressure converter is closed at a pulse duty factor of 6% and ambient pressure is applied.

The Electro-pneumatic pressure converter is fully open at a pulse duty factor of 98% and the maximum vacuum of the vacuum system is applied.



Index	Explanation
1	Vacuum connection
2	Vacuum outlet
3	Filter element
4	Electric plug connection

Electric Changeover Valve

The electric changeover valve is used for components that switch in two positions. The electric changeover valve makes it possible to switch either no vacuum or the maximum available vacuum from the vacuum connection (1) to vacuum outlet (2).

In contrast to the Electro-pneumatic pressure converter, here no mixed pressure is set but rather the vacuum in the system is switched through to the vacuum unit.

On the M57D30T2 engine, this electric changeover valve is used for the variable engine mounts and the compressor bypass valve.

The electric changeover valve is actuated by the DDE.



Index	Explanation
1	Vacuum connection
2	Vacuum outlet
3	Electric plug connection

NOTES

PAGE

Exhaust Turbocharger

The turbocharger is driven by the engine's exhaust gases. The hot, pressurized exhaust gases are directed through the turbine of the exhaust turbocharger, thus producing the drive force for the compressor.

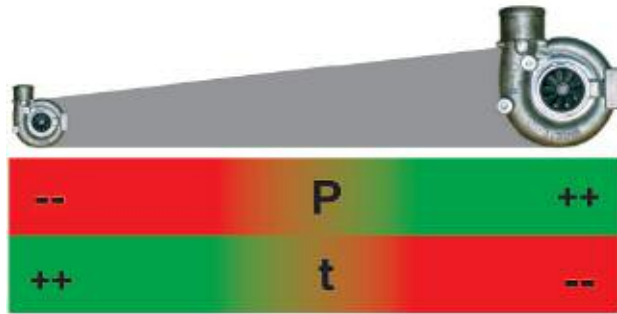

Index	Explanation
P	Engine output
t	Response characteristic

The intake air is pre-compressed so that a higher air mass enters the combustion chamber in the engine. In this way, it is possible to inject and combust a greater quantity of fuel, which increases the engine's power output and torque.

The speeds of the turbine are between 100,000 rpm and 200,000 rpm. The exhaust inlet temperature may be up to approximately 900°C.

The performance of a turbocharged engine can reach the levels achieved by a naturally aspirated engine with significantly more capacity. However, the boost effect can also be used in a small engine to achieve a certain output with comparatively reduced consumption.

Twin Turbocharging

Due to the operating principle as previously mentioned, the design of a turbocharger always involves a conflict of objectives. A small exhaust turbocharger responds quickly and provides ample torque at low engine speeds. However, its power output is limited as it quickly reaches the surge and choke line. Although it can generate high pressures, the volumetric flow is limited due to its size.

A large exhaust turbocharger is capable of producing high power output levels at high engine speeds. However, it responds sluggishly and is not capable of generating a high boost pressure at low engine speeds.

The ideal solution would be to have two exhaust turbochargers. One small turbocharger for quick response and one large turbocharger for maximum output yield.

Precisely this configuration has now been developed for BMW twin turbo diesel engines. Two series-connected exhaust turbochargers are used.

A small turbocharger for the high pressure stage and a larger turbocharger for the low pressure stage. The two turbochargers do not have variable vanes.

The two turbochargers can be variably combined providing an optimum for the entire operating range. This interplay is made possible by various flaps and valves.

These are:

- Turbine control valve (exhaust side)
- Compressor bypass valve (air side)
- Wastegate (exhaust side)

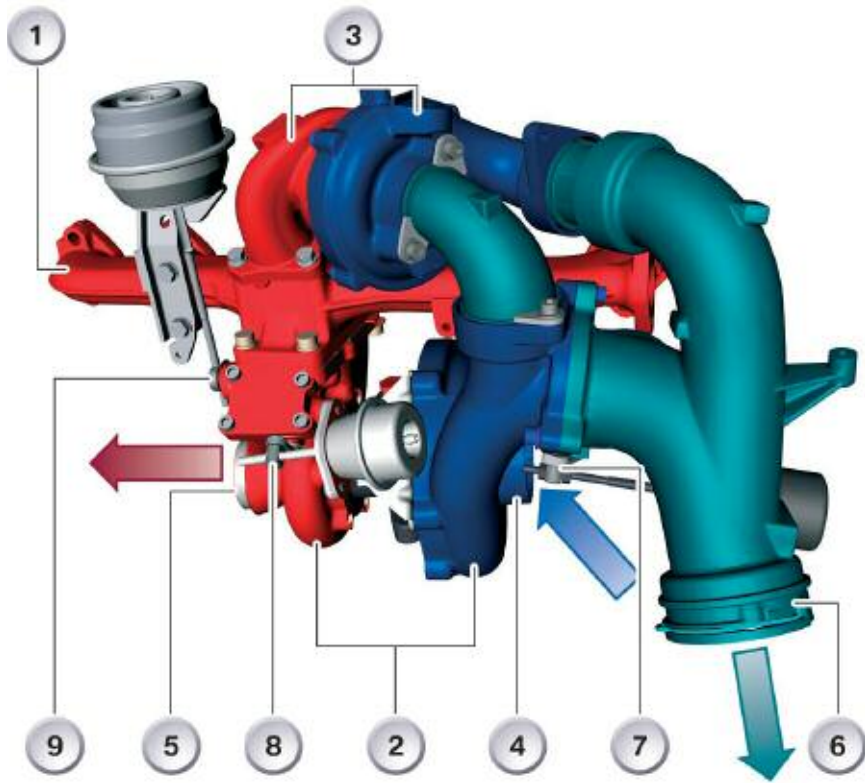

■ High Pressure Stage

The high pressure stage is the smaller of the two exhaust turbochargers. This is designed as a so-called "integral manifold" as the housing for the exhaust turbocharger and the exhaust manifold are one single cast unit. The high pressure stage is not connected by a valve. The oil inlet and outlet provides the necessary lubrication of the bearing.

■ Low Pressure Stage

The large exhaust turbocharger houses the turbine control valve and wastegate. It is mounted on the exhaust manifold and is additionally supported against the crankcase. The low pressure stage also has a separate oil supply for the bearing.

■ Turbine Control Valve

The turbine control valve opens a bypass channel on the exhaust side to the low pressure stage (past the high pressure stage). It is operated pneumatically by a vacuum unit and can be variably adjusted. An Electro-pneumatic pressure converter (EPDW) applies vacuum to the vacuum unit. In development, the turbine control valve is referred to as the main control valve.

■ Compressor Bypass Valve

The compressor bypass valve controls the bypass of the high pressure stage on the air intake side. It is operated pneumatically by a vacuum unit. The compressor bypass valve is either fully opened or completely closed. An electric changeover valve (EUV) applies vacuum to the vacuum unit.

■ Wastegate

On reaching the nominal engine output, the wastegate opens to avoid high boost and turbine pressures. A part of the exhaust gas flows via the tailgate past the turbine of the low pressure stage. It is operated pneumatically by a vacuum unit. The wastegate can be variable adjusted.

Index	Explanation
1	Exhaust manifold
2	Exhaust turbocharger - low pressure stage (large turbo)
3	Exhaust turbocharger - high pressure stage (small turbo)
4	Intake air inlet from air cleaner
5	Exhaust system connection
6	Outlet of compressed intake air to intercooler
7	Compressor bypass valve
8	Wastegate
9	Turbine control valve

Two-Stage Turbocharging Function

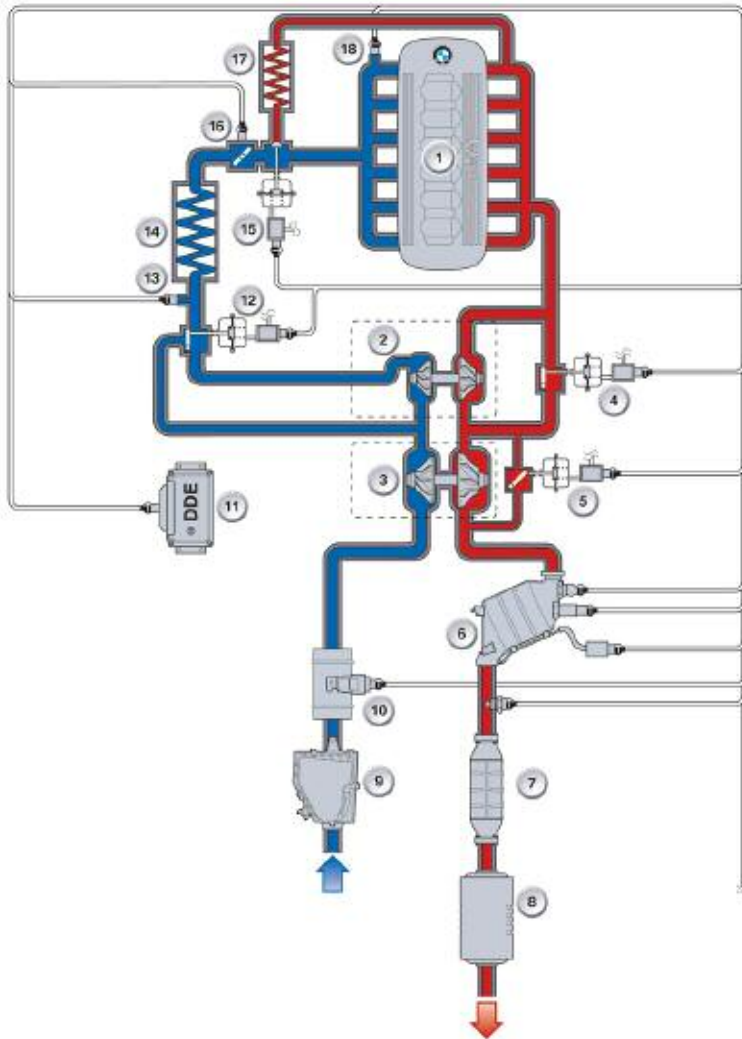

■ Turbine Control Valve

The turbine control valve (4) routes the exhaust gas through the bypass duct past the high pressure stage (2) to the low pressure stage (3). It is operated pneumatically by a diaphragm unit and can be variably adjusted. An Electro-pneumatic pressure converter (high speed EPDW) applies vacuum to the diaphragm unit.

Index	Explanation	Index	Explanation
1	M57TU1-TOP engine	10	Hot-film air mass meter (HFM)
2	Exhaust turbocharger (high pressure stage)	11	Digital diesel electronics (DDE)
3	Exhaust turbocharger (low pressure stage)	12	Compressor bypass valve with electric changeover valve (EUV)
4	Turbine control valve with electropneumatic pressure converter (EPDW)	13	Intake air temperature sensor
5	Wastegate with electropneumatic pressure converter (EPDW)	14	Intercooler
6	Oxidation catalytic converter	15	Exhaust gas recirculation (EGR valve)
7	Diesel particle filter	16	Throttle valve
8	Rear silencer	17	EGR cooler
9	Intake silencer (AGD) with air cleaner	18	Boost pressure sensor

■ Compressor Bypass Valve

The compressor bypass valve (12) controls the bypass of the high pressure stage (2) on the air intake side. It is operated pneumatically by a diaphragm unit. The compressor bypass valve is either fully opened or completely closed. An electric changeover valve (EUV) applies vacuum to the diaphragm unit.

■ Wastegate

On reaching the nominal engine output, the wastegate (5) opens to avoid high boost and turbine pressures.

A part of the exhaust gas flows via the tailgate past the turbine of the low pressure stage (3). It is operated pneumatically by a diaphragm unit. The wastegate can be variably adjusted. An Electro-pneumatic pressure converter (EPDW) applies vacuum to the diaphragm unit.

■ **Lower Engine Speed Range (up to 1500 rpm)**

The turbine wheels of the high pressure and low pressure stages (6+7) are driven by exhaust gas. The engine is supercharged primarily by the high pressure stage (7).

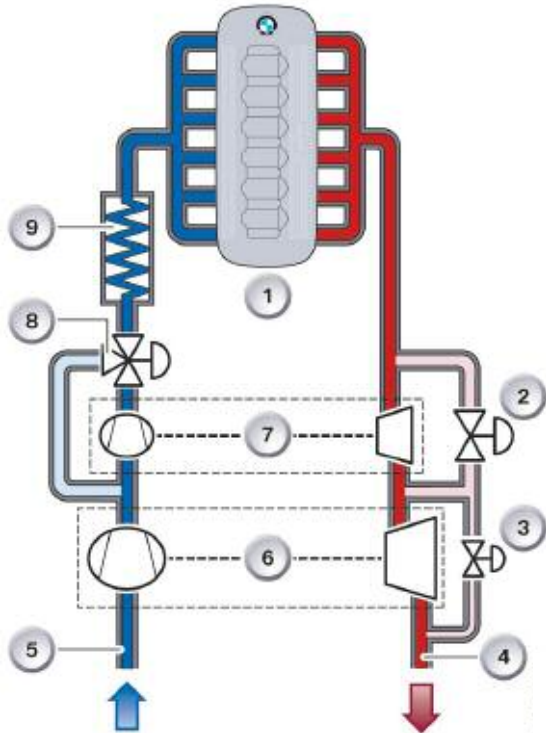

■ **Medium Engine Speed Range (from 1500 to 3250 rpm)**

The turbine control valve (2) opens continuously as the engine speed increases. Consequently, the flow of exhaust gas increasingly bypasses the turbine wheel of the high pressure stage (7).

As the engine speed increases, the engine is supercharged more and more by the low pressure stage (6).

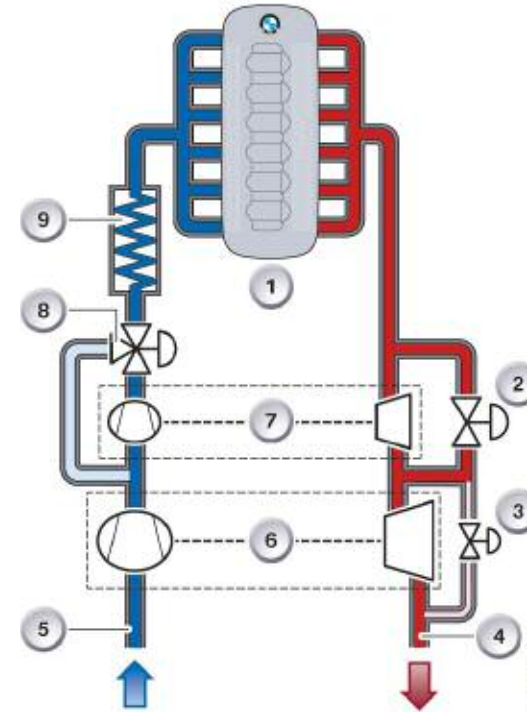

Index	Explanation	Index	Explanation
1	M57D30T2 Engine	6	Exhaust turbocharger - low pressure stage
2	Turbine control valve with electro-pneumatic pressure converter (EPDW)	7	Exhaust turbocharger - high pressure stage
3	Wastegate with electro-pneumatic pressure converter (EPDW)	8	Compressor bypass with electric changeover valve (EUV)
4	Exhaust gas to exhaust system	9	Intercooler
5	Fresh air from air cleaner		

■ Upper Engine Speed Range (from 3250 to 4200 rpm)

The turbine control valve (2) is completely open. The flow of exhaust gas largely bypasses the turbine wheel of the high pressure stage (7). The compressor bypass valve (8) is open. The engine is supercharged only by the low pressure stage (6).

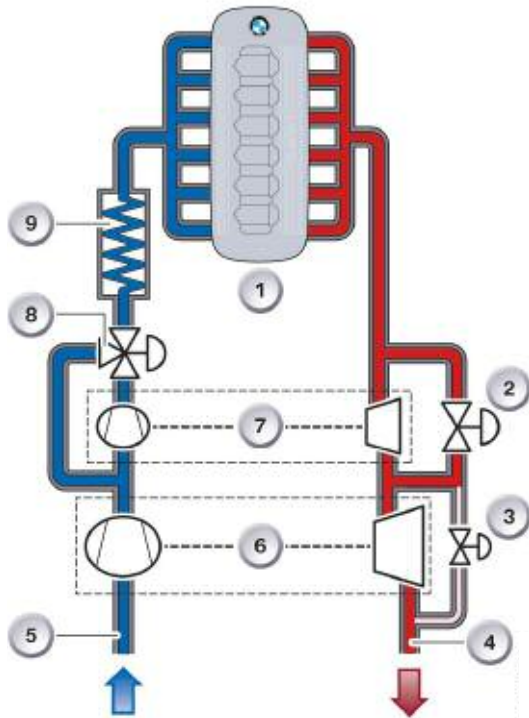

■ Nominal Engine Speed Range (as from 4200 rpm)

The engine is supercharged by the low pressure stage (6). The wastegate (3) opens as the engine speed increases. A part of the exhaust gas therefore bypasses the turbine wheel of the low pressure stage, thus limiting the turbine speed.

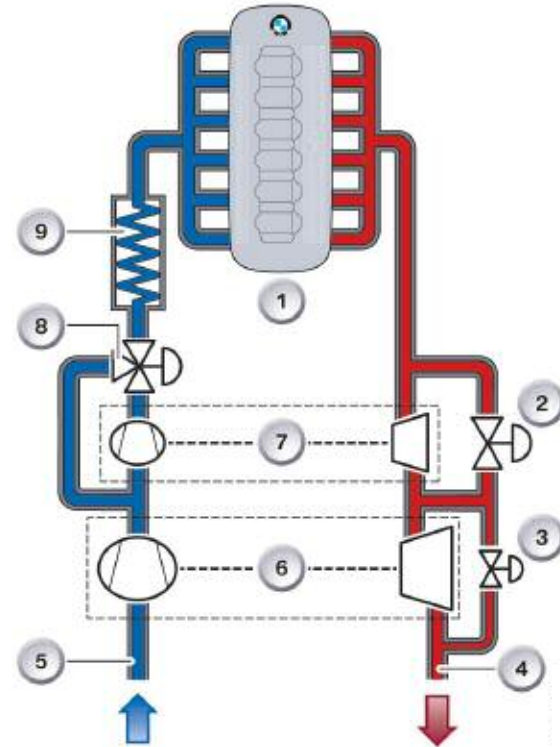

Index	Explanation	Index	Explanation
1	M57D30T2 Engine	6	Exhaust turbocharger - low pressure stage
2	Turbine control valve with electro-pneumatic pressure converter (EPDW)	7	Exhaust turbocharger - high pressure stage
3	Wastegate with electro-pneumatic pressure converter (EPDW)	8	Compressor bypass with electric changeover valve (EUV)
4	Exhaust gas to exhaust system	9	Intercooler
5	Fresh air from air cleaner		

NOTES

PAGE

Diesel Emission Controls

In a diesel engine, power output is dependent upon the amount of diesel fuel injected. The engine is operated in a very lean mode with excess air. The available excess air provides enough oxygen for more complete combustion. This lean operation reduces the overall Hydrocarbon (HC) and Carbon Monoxide (CO) emissions as compared to a gasoline engine. However, due to the higher combustion chamber temperatures, Oxides of Nitrogen (NO_x) are a major concern.

Other concerns in a diesel engine include soot which is also known as Particulate Matter (PM). PM can be controlled in the engine or via exhaust after-treatment.

Diesel engine emissions can be controlled in one of 2 ways. One method is via what is known as “in engine” measures which are accomplished by changes in engine design or by the diesel engine management systems. The engine management system can control emissions via the fuel injection strategy.

Emissions which cannot be controlled via the engine or engine management are the responsibility of the “after-treatment” system. Some of the methods employed as after-treatment systems are diesel oxidation catalysts, particulate filters and the new Selective Catalytic Reduction (SCR) systems.

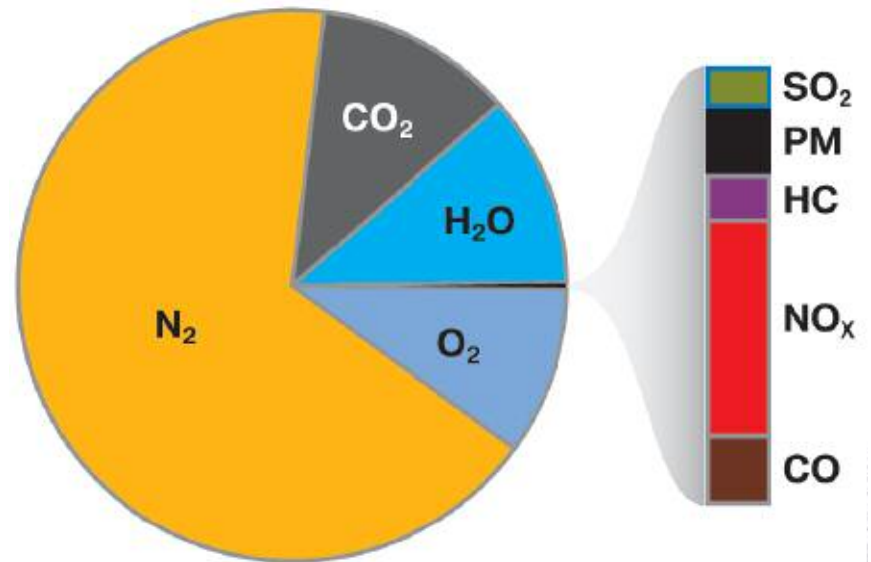

Exhaust Gas Constituents before Exhaust Treatment

Combustion By-products

Exhaust gases are the by-product of a chemical reaction which occurs during the combustion process. Since diesel fuel is a hydrocarbon, the composition of the exhaust gas is similar to the exhaust gasses from a gasoline engine. However, these gasses are present in different percentages due to the lean operation of the diesel engine.



Hydrocarbons (HC)

Diesel fuel is a hydrocarbon, therefore any hydrocarbons that are present in the exhaust stream are considered unburned (or un-combusted). HC is a generic term for any chemical compound which unites Hydrogen (H) with Carbon (C). During combustion, new HC compounds are produced which are not initially present in the original fuel.

The HC is produced when there is insufficient oxygen to support complete combustion or if there are cylinder misfires. HC emissions are also produced in the “cooler” parts of the combustion chamber such as the area around the piston rings. These “cool” areas tend to quench the flame front, resulting in “un-combusted” hydrocarbons. A cold engine also tends to allow fuel to condense on the cylinder wall which has the same “quenching” effect.

Diesel engines do not produce a high level of HC, and most of the remaining HC after combustion is oxidized by the diesel oxidation catalyst (DOC).

Effects of HC Emissions

Hydrocarbon emissions are a component of ground level ozone which has become an issue in many cities across the US. As one of the primary building blocks of smog, ground level ozone is created by chemical reactions between HC and nitrogen oxides in the presence of sunlight.

Ozone at ground level contributes to numerous health problems including lung damage and cardiovascular functions. Also, hydrocarbons are also considered toxic.

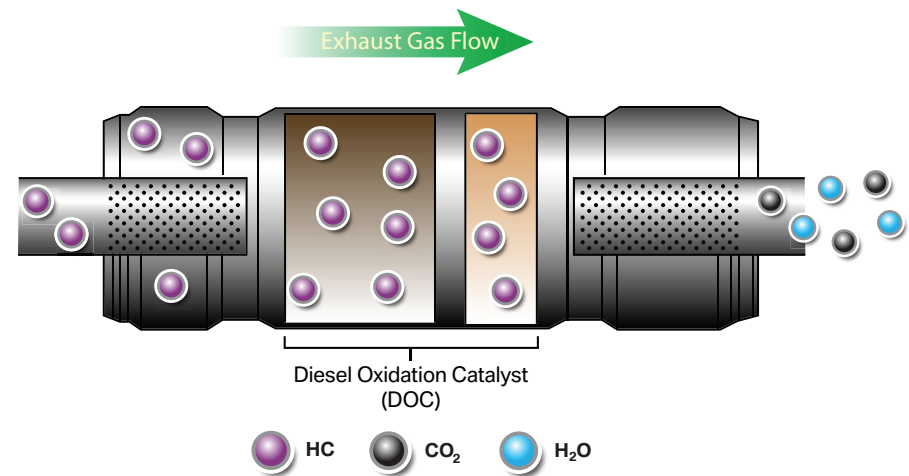

Carbon Monoxide

Carbon Monoxide (CO) is formed when there is insufficient oxygen to support combustion. This condition results in partially burned fuel. During normal combustion, Carbon atoms combine with oxygen atoms to produce Carbon Dioxide (CO₂) and water vapor. When there is a lack of oxygen (or excess fuel) during combustion, Carbon Monoxide is formed.

Carbon Monoxide is not usually a concern in modern “lean burn” diesel engines. Output of CO is minimal in a diesel engine and most of the residual CO is processed (oxidized) by the diesel oxidation catalyst.

Effects of CO Emissions

Carbon Monoxide is a colorless, odorless and tasteless gas which is poisonous to humans and other air breathing creatures. When inhaled, CO takes the place of oxygen in red blood cells. Red blood cells normally transport oxygen to all of the bodies tissues. When oxygen is substituted by CO in the bloodstream, a condition known as hypoxia occurs. This ultimately causes asphyxiation which can result in severe illness or death. Even in small amounts, CO can cause illness and headaches.

In the environment, CO contributes to the “greenhouse” effect. Although CO is considered a primary pollutant today, it has always been present as a result of brush fires and volcanic activity.

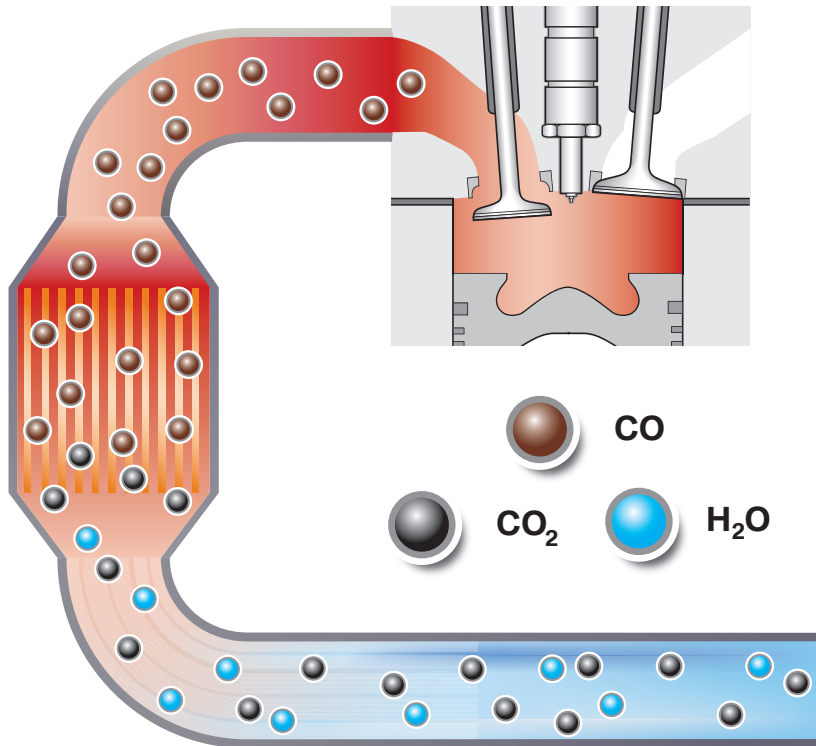

Oxides of Nitrogen (NO_x)

NO_x is an all-inclusive term for chemical compounds consisting of nitrogen (N) and oxygen (O). NO_x consists of mostly NO (Nitric Oxide) and NO₂ (Nitrogen Dioxide).

Since the ambient air contains both Nitrogen and Oxygen, NO_x is formed when these two elements combine in the heat of combustion. Nitrogen and Oxygen do not combine until the combustion chamber temperature exceeds 1100°C.

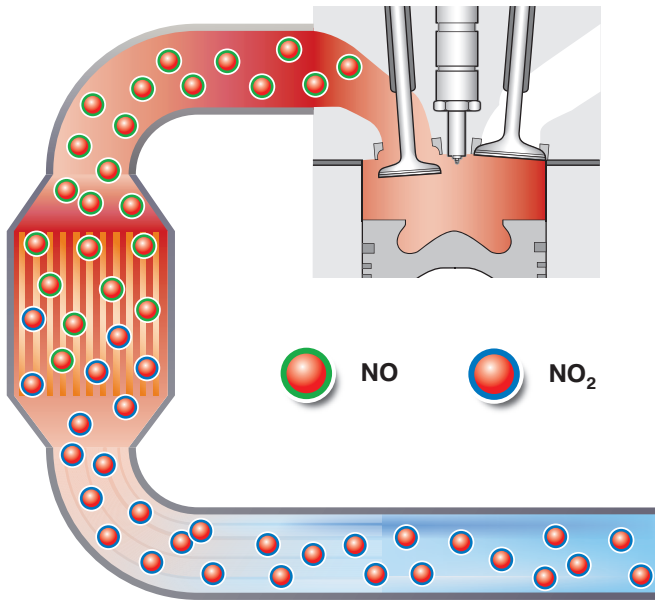

One of the major factors in the formation of NO_x is the overall combustion chamber temperature. Diesel engines have inherent issues regarding the production of NO_x.

Due to the fact that diesel engines have a very high compression ratio, the combustion chamber temperatures are, of course, high as well. This in turn, initiates the optimal conditions for NO_x formation. Also, the lean mixtures in a diesel engine contribute to additional available oxygen in the combustion chamber. This, in turn, is a factor in the higher combustion chamber temperatures.

More than 50% of NO_x emissions are derived from mobile sources i.e cars, trucks and buses etc.. This includes “on-road” as well as “off-road” sources.

NO_x reduction can be addressed by engine management or by exhaust “after-treatment”.

■ Effects of NO_x Emissions

NO_x emissions, along with HC and sunlight, contribute to the formation of photochemical smog. Smog is attributable to numerous health issues and is classified by the E.P.A. as major contributor to health issues including respiratory and heart related illnesses.

NO_x is also responsible for the formation of ground level ozone, which is also a major irritant of the respiratory system. Ozone is of particular concern to those suffering from asthma.

In the environment, both ozone and NO_x are considered to be of the major greenhouse gasses which contribute to global warming.

Particulate Matter

One area where diesels are less than desirable is in the area of particulate matter emissions or “PM”. PM emissions are more commonly referred to as soot. Although diesel engines emit less HC and CO, soot is derived from any unburned fuel. Sulfur is one of the origins of soot in diesel exhaust. The reduction of sulfur content in the fuel is one way to reduce overall PM emissions.

Particulate matter emissions are classified in two groups which are based on particle size. PM10 refers to those particulates which are less than or equal to 10 microns and PM2.5 has a particle size of 2.5 microns or less.

Diesel exhaust consists of mostly the smaller (PM2.5) particles. Particulate matter is considered a harmful pollutant which contributes to respiratory problems. Therefore, PM emission should be controlled.

PM emissions can be reduced in a number of ways. One of the first and most practical measures is to reduce the sulfur content in the fuel. As of 2007, the new ULSD fuel has a limit of 15 ppm sulfur. This represents a major reduction over the former 500 ppm limit.

Engine design and engine management systems can greatly contribute to a reduction in PM emissions by ensuring the most efficient engine operation. Perhaps the most effective method of reducing PM emissions is found in the exhaust after-treatment systems.

The diesel oxidation catalyst (DOC) has proven to be somewhat effective in breaking down the constituents of PM. However, the DOC is not enough to meet the current emission standards regarding particulate matter emissions. This is where the diesel particulate filter (DPF) becomes an important element of overall PM reduction.

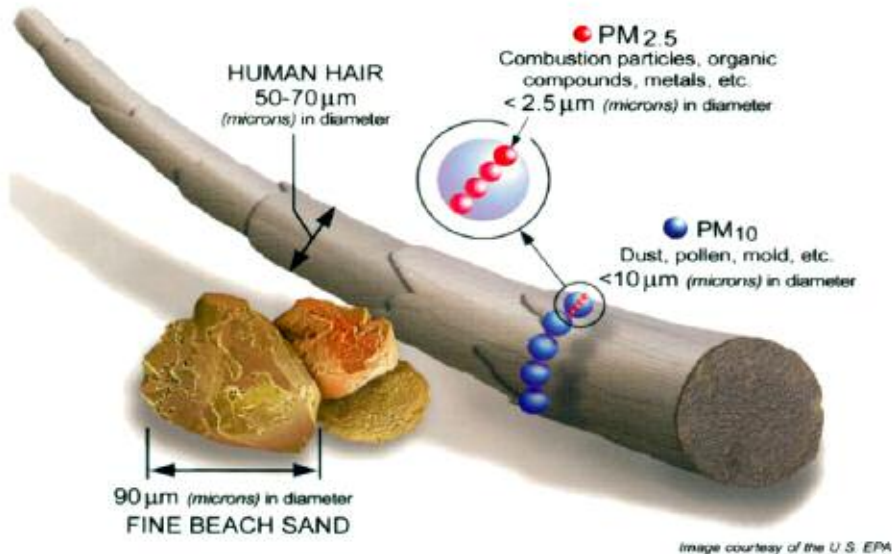

Carbon Dioxide

Carbon dioxide (CO₂) is one of the constituents in the exhaust of any internal combustion engine. When an engine is running in its most efficient state, the major portion of the exhaust gas consists of carbon dioxide and water. As a matter of fact, it can be said that the efficiency of an engine can be measured by the CO₂ content in the exhaust.

Carbon Dioxide Molecule

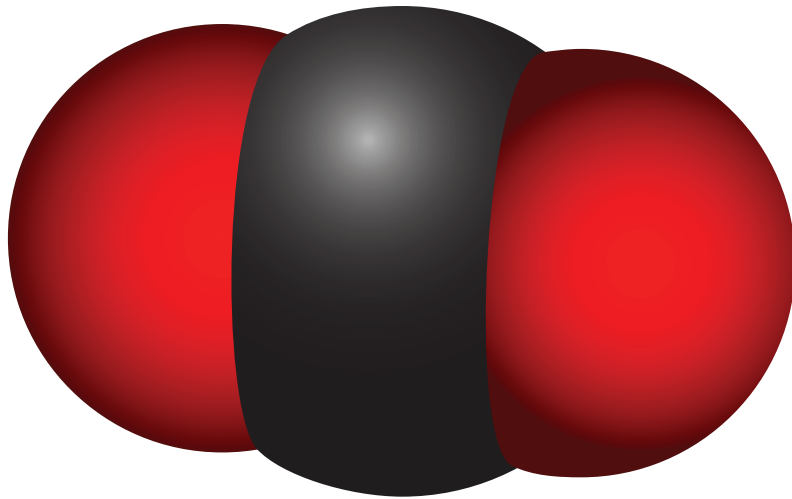

Ironically, CO₂ is one of the major contributors to the theory of global warming. Although CO₂ is a natural, non-toxic component of the earth's atmosphere it is now present in a disproportionate amount. Scientists agree that this situation is now contributing to the warming of our global environment. It is also important to note that atmospheric CO₂ is not only the result of automobile emissions, but overall industrialization from sources such as manufacturing, power generation and transportation sectors.

Since CO₂ production in an internal combustion engine is a measure of an engine's overall efficiency, reducing CO₂ output is a challenge.

Since CO₂ output is directly proportional to the amount of fuel consumed, it would make sense to improve overall fuel economy. Currently, the best way to reduce CO₂ output is to improve the overall efficiency.

Some of these new measures on BMW diesel vehicles include:

- The addition of Electric Power Steering (EPS) which reduces the parasitic load of hydraulic (belt driven) power steering
- The addition of an A/C compressor clutch (previous models omitted clutch)
- Lightweight vehicle and engine construction
- Tires with reduced rolling resistance (future)

The items mentioned above are just a few of the measures to reduce CO₂ emissions. As part of BMW's "Efficient Dynamics" concept, many new advances in "clean" diesel technology are on the horizon.

When reducing CO₂ output by way of engine measures, the resulting leaner operation results in increased NO_x output. In the future these situations will be countered by Selective Catalytic Reduction (SCR).

Diesel Emission Control Systems

Taking all of the positive aspects of diesel engines into consideration, perhaps the most challenging aspect of diesel engine design is the reduction of emissions. Diesel engines are much more efficient than gasoline engines, but have some inherent emission concerns due to the fuel used and the lean running strategy.

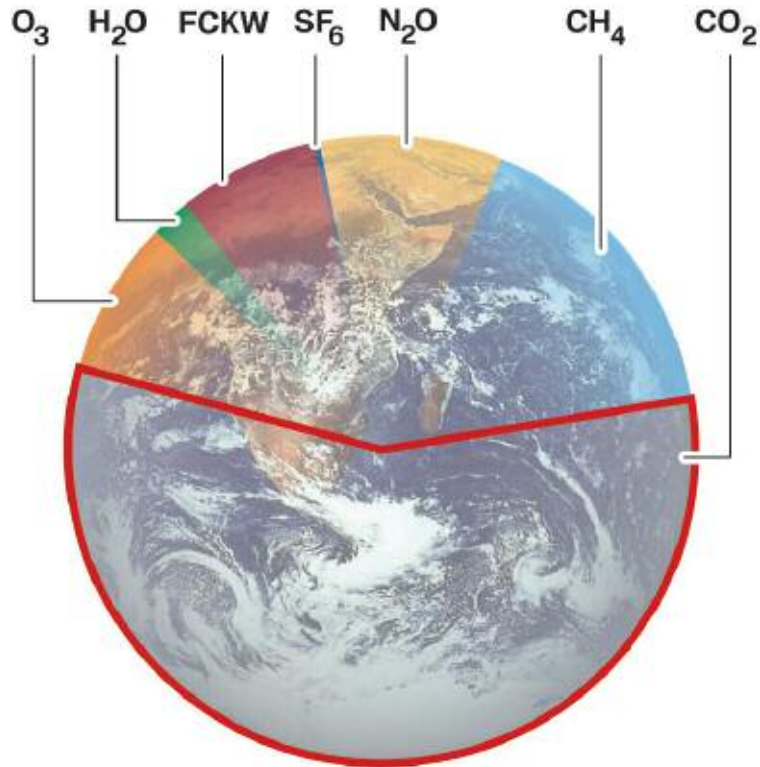

Diesel engines have a high combustion chamber temperature which contributes to excessive NO_x production. The high combustion chamber temperatures are due to the high energy content of diesel fuel and the lean mixture. The lean mixture does not have the same cooling effect of the “richer” mixture found in gasoline engines.

Gasoline engines run at the “stoichiometric” ratio of 14.7 to 1 otherwise known as $\lambda = 1$. Diesel engines have a variable air/fuel ratio which varies between a λ value of 1.15 to 2.0. Under idle and no load conditions this could increase to a λ value of 10.

Particulate emissions are also a concern in diesel engines due to the sulfur content in the fuel used. Even though most new diesel vehicles will run on ULSD diesel, the PM emissions are still high enough to be a concern. So, measures must be taken to reduce the overall soot content in the exhaust.

On diesel engines, the reduction of emissions can be classified into two major categories.

The two categories include:

- “In-engine” measures
- Exhaust after-treatment

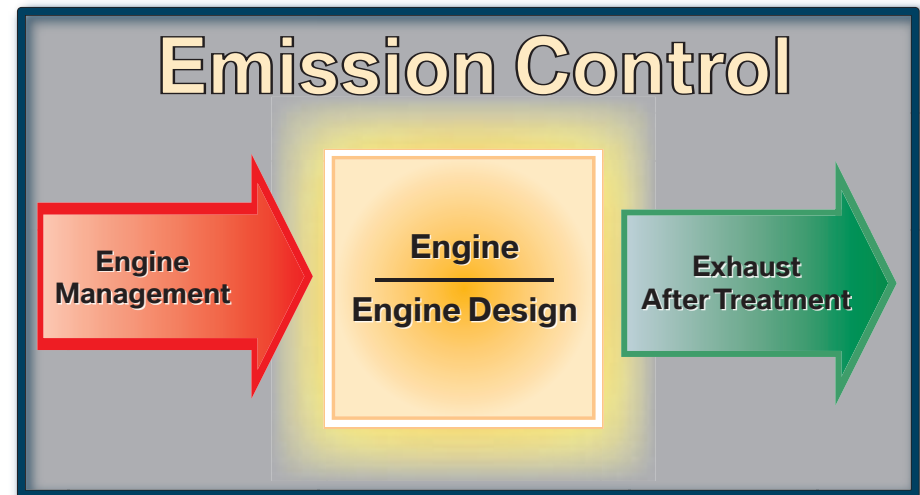

Engine Measures to Reduce Emissions

The “in-engine” measures include design elements in the mechanical structure of the engine as well as engine management intervention. In order to reduce unwanted levels of emissions, the engine design should contribute to the best possible level of efficiency.

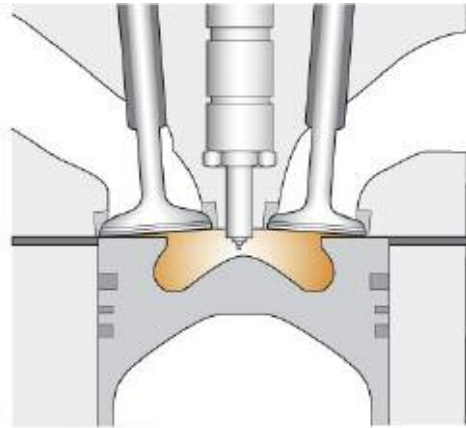

For example, the shape of the combustion chamber has an effect on fuel mixing. The mixture can be influenced or “shaped” by the piston design and the angle at which the fuel is injected. The intake manifold and intake ports can be designed to provide more air motion in the combustion chamber. This is referred to as the “swirl effect”. By providing this air movement via “swirl”, the air is better mixed with the atomized fuel and thus contributes to lowered emissions.

At low RPM the swirl in the combustion chamber lowers NO_x values in the lower RPM range. BMW engines take advantage of this by using an intake manifold with swirl flaps which can be controlled via the diesel engine management (DDE).

If the swirl flaps stick open, low RPM emissions will be affected. If the swirl flaps stick closed, high RPM power will be noticeably reduced.

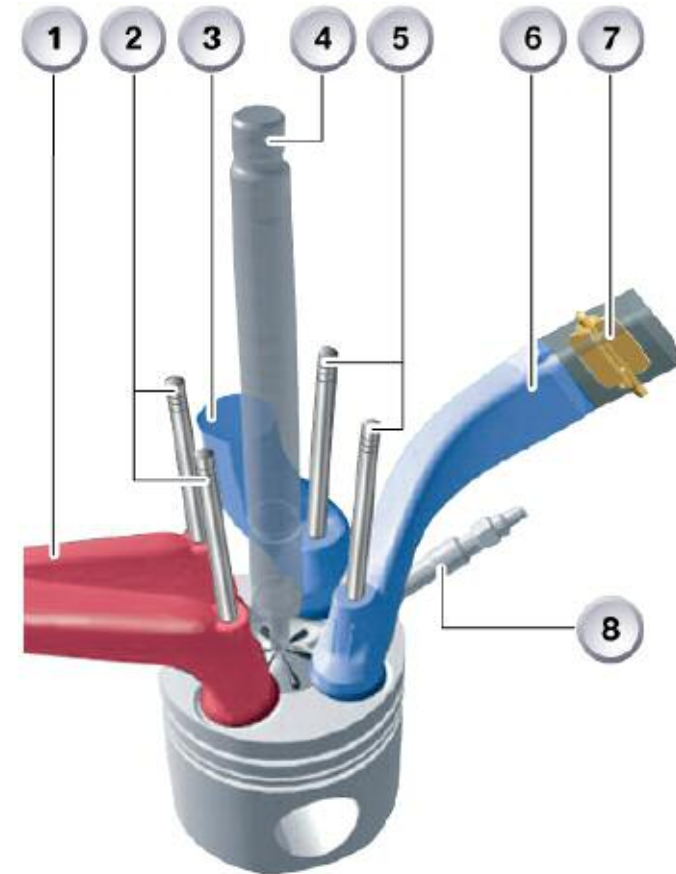

Index	Explanation	Index	Explanation
1	Exhaust ports	5	Intake valves
2	Exhaust valves	6	Intake (tangential) port
3	Swirl Port	7	Swirl flap
4	Fuel injector	8	Glow plug

Injection Strategy

Besides mechanical methods, the engine management system can influence overall emission output. This strategy is carried out via the fuel injection system. Modern diesel fuel injection systems are very precise and use extremely high pressures to improve overall efficiency and emission levels.

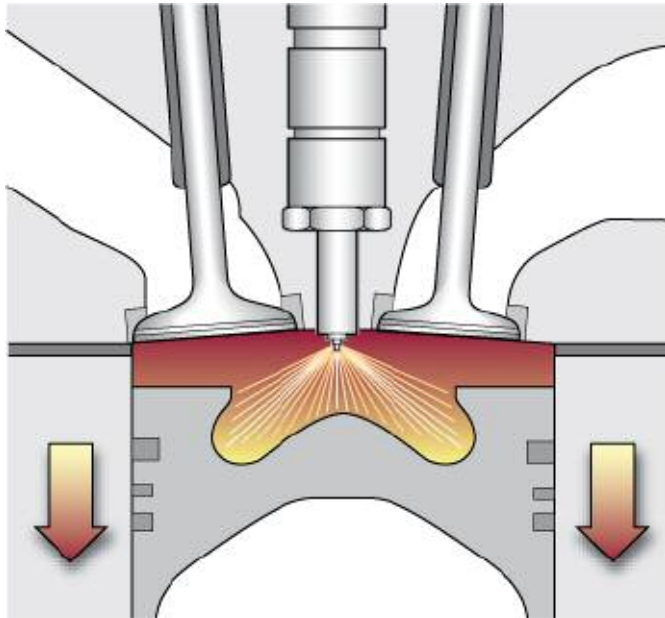

The injection system on a diesel engine functions, in some ways, much like an ignition system on a gasoline engine. In order to start combustion, it is necessary to inject fuel at the right time with reference to the position of the piston. Just like an ignition system on a gasoline engine, the injector must inject fuel before top dead center (BTDC).

The injection strategy can also be modified to inject fuel at different times (i.e. ATDC) and can have multiple injection events. Fuel can be injected ATDC to help the catalyst achieve operating temperature earlier. The injection strategy can also be modified to assist in heating the DPF (DPF is discussed in the “Exhaust after-treatment” section of this workbook).

For example, the start of injection can be between 2 and 4 degrees BTDC when there is no load present (such as during idle). Under full load conditions, the start of injection can be moved to 15 degrees BTDC.

However, starting the injection event too early can be counterproductive. The early start of combustion can actually resist the movement of the piston and cause a loss of power and an increase in emissions.

■ Multiple Injection

The introduction of the third generation common rail facilitates finer distribution of the fuel injection per power stroke. Instead of injecting the fuel in two stages per power stroke (pre-injection for minimizing noise and main injection for developing power) as was previously the case, the fuel is now injected in up to 3 stages.

As a result, the engines run even more quietly and produce less nitrogen oxides and soot particles.

The following factors enable triple injection:

- Increased processing capacity of the DDE
- Higher efficiency of the coils in the fuel injectors

Operating Range	M57 TU Injection Strategy
Near Idle Speed	2 pre-injections 1 main-injection
Partial Load	1 pre-injection 1 main-injection 1 post-injection
Full Load	1 pre-injections 1 main-injection
Maximum Output	1 main-injection

Charge Air Cooling

More commonly known as intercooling, BMW turbo-diesel engines benefit from charge air cooling in several ways. Besides increasing charge air density, the intercooler also reduces NO_x as an added benefit of the reduced charge air temperature.

Usually, the intercooler is not associated as being an emission control device. But, due to the high combustion chamber temperature in a diesel engine the intercooler is now providing an important function with regard to NO_x reduction.

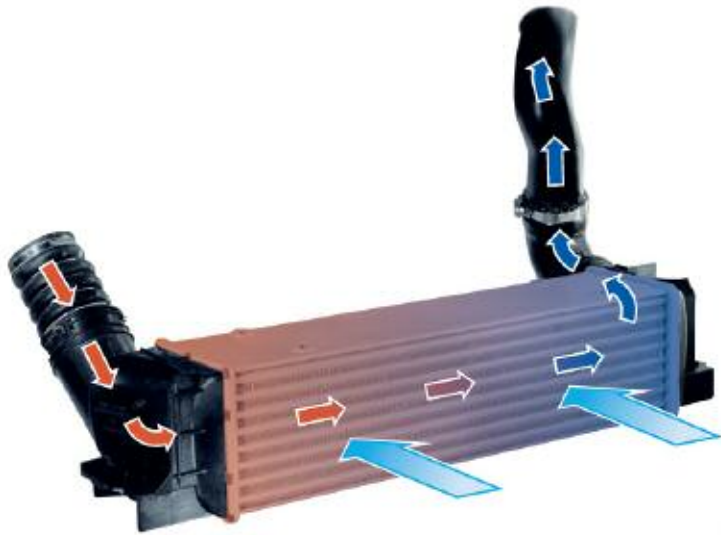

Exhaust Gas Recirculation (EGR)

BMW gasoline engines currently, do not use a more conventional “external” EGR system. EGR on BMW gasoline engines is considered an “internal” system which is carried out via the variable camshaft control system (VANOS).

The VANOS system modifies the camshaft timing to achieve a precise amount of valve overlap. The valve overlap allows a certain amount of EGR to occur, thus lowering NO_x significantly.

Mostly, gasoline engines respond to an EGR flow rate of about 5 to 15%. BMW gasoline engines are able to benefit from the “internal” method of EGR due to engine design and the engine management strategies.

In the case of diesel engines, which run in a constantly lean mode, the NO_x content in the exhaust gas is much higher. Therefore, the “internal EGR” method is not able to sufficiently lower NO_x to acceptable levels. So, BMW diesel engines employ an external EGR system to meet these needs. Diesel engines benefit from EGR rates as high as 50% under certain operating conditions.

Unlike gasoline engines, diesels can introduce EGR at idle. This is due to the fact that the diesel has a mostly open throttle at idle. This helps reduce NO_x at idle which is when a diesel is most lean.

The recirculated exhaust gas, which is mixed with the fresh air and acts as an inert gas, serves to achieve the following:

- A lower oxygen and nitrogen concentration in the cylinder,
- A reduction in the maximum combustion temperature of up to 500°C . This effect is increased still further if the recirculated exhaust gases are cooled.

The EGR valve is located in the throttle housing. Exhaust gas is ducted from the exhaust manifold to the throttle housing. There is a connection at the forward end of the manifold for this purpose. Connected here is the EGR valve, which controls the volume of recirculated exhaust gas.

■ EGR Control

The EGR valve opens by applying vacuum at vacuum connection (9). The vacuum presses diaphragm (1) against spring (10) and the EGR valve head (3) is lifted from blade-type sleeve (4). Exhaust gas (5) can now flow past the EGR valve head into the intake port.

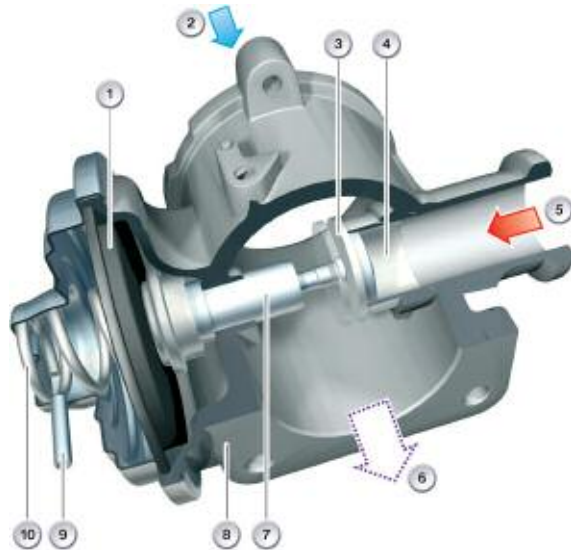

Index	Explanation
1	Diaphragm
2	Intake air from throttle valve
3	EGR Valve head
4	Blade type sleeve
5	Incoming exhaust gas
6	Fresh air/Exhaust gas mixture
7	Guide sleeve
8	EGR housing
9	Vacuum connection
10	Spring

The exhaust gas now mixes with the intake air from throttle valve (2) and is directed in the form of a fresh air-exhaust gas-air mixture (6) to the engine. The blade-type sleeve has the advantage that, when the EGR valve is closed, any deposits formed on the sleeve are removed by the blade shape, ensuring the EGR valve always closes reliably. In this way, a coking ring is prevented from forming on the surface of the valve seat.

■ EGR Cooling

The use of an EGR cooler increases the efficiency of exhaust gas recirculation. The cooled exhaust gas is able to draw off more thermal energy from the combustion and thus reduce the maximum combustion temperature. Actually, the “cooled” exhaust gas will allow a greater volume of exhaust gas to be recirculated.

The EGR cooler is located in the forward end face of the cylinder head. It is supplied with coolant from the cooling system in the crankcase directly downstream of the coolant pump. The coolant flows through the EGR cooler and, in the process, around the pipes carrying the recirculated exhaust gas. Heat is transferred to the coolant. After passing through the EGR cooler, the coolant flows into the cylinder head.



Exhaust After-treatment

Diesel Oxidation Catalyst (DOC)

The DOC is responsible for specific functions in the after-treatment of diesel exhaust. It is mounted as close to the engine as possible for maximum effectiveness over the entire operating range of the engine.

The functions are as follows:

- Reduction in HC emissions
- Reduction in CO emissions
- Oxidation of NO into NO₂
- Reduction of particle mass
- To increase exhaust temperature for the regeneration phase of the DPF

In most systems, Diesel Oxidation Catalysts (DOC's) consist of a stainless steel canister that contains a honeycomb structure called a substrate or catalyst support. It contains no moving parts, only an interior surface coated with catalytic metals such as platinum or palladium.

The DOC is mounted as close to the engine as possible to take advantage of available exhaust heat.

The exhaust in a diesel engine does not contain high amounts of HC and CO, but these gasses must be converted into more harmless gasses.

Note: Newer diesel vehicles incorporate the DOC and the DPF in the same housing.

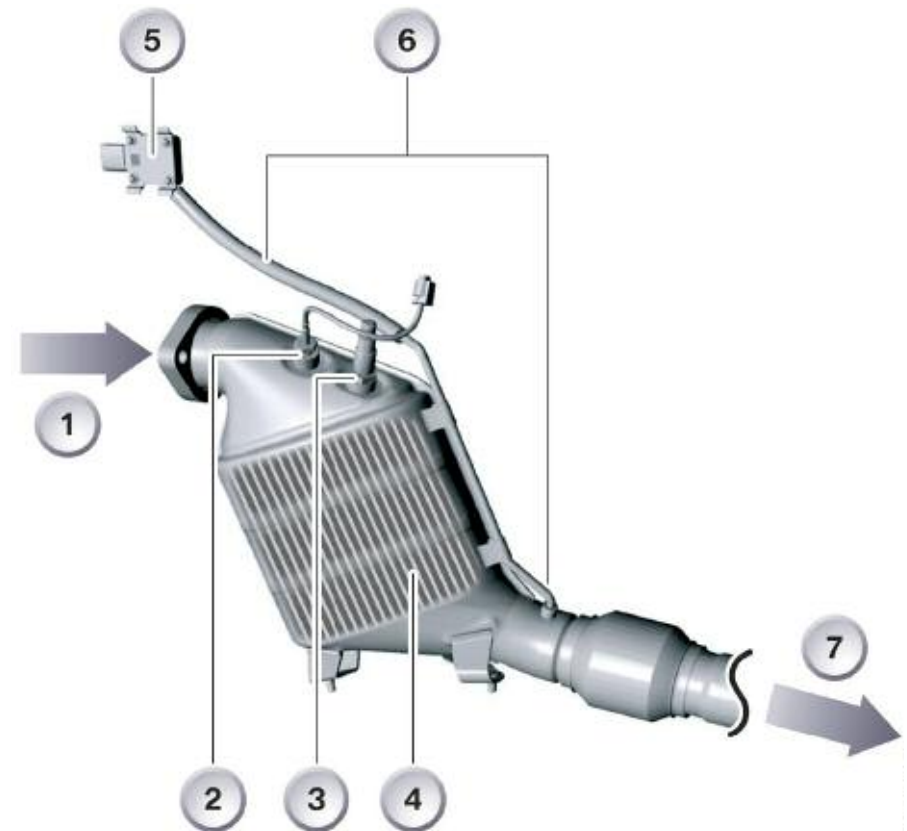

Index	Explanation	Index	Explanation
1	Exhaust gasses (pre-cat)	5	Exhaust pressure sensor
2	Exhaust gas temperature sensor	6	Pressure tube
3	Oxygen sensor	7	Exhaust gas
4	DOC housing		

■ Reduction of Unwanted Emissions

The near-engine oxidation catalytic converter ensures the conversion of the following exhaust gas constituents across the entire operating range:

- Carbon monoxide (CO) is converted into carbon dioxide (CO₂)
- Hydrocarbons (HC) are converted into water (H₂O) and carbon dioxide (CO₂)
- Nitrogen monoxide (NO) is converted into nitrogen dioxide (NO₂)
- Soot particles are also reduced in the DOC by about 15 to 30%

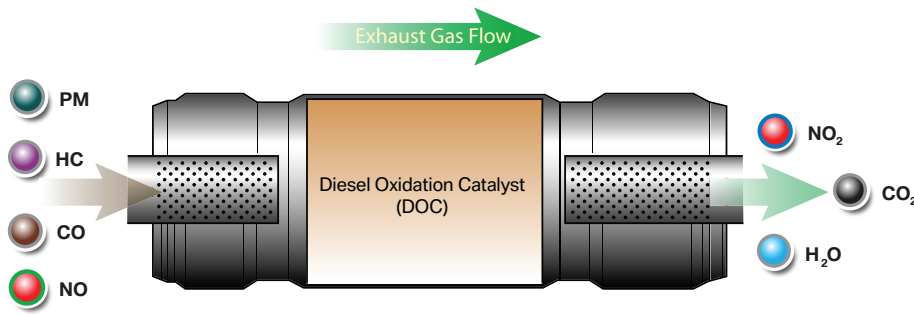

Soot particles flow through the oxidation catalytic converter unimpeded. The oxidation catalytic converter is additionally used to increase the temperature during regeneration of the diesel particulate filter. The ceramic carrier (cordierite) features a platinum-based oxidation coating.

The resulting NO₂ from the conversion process is also used downstream in the particulate filter (DPF) and in the SCR system.

Due to the high oxygen content of the exhaust gas, the oxidation catalytic converter starts to work at approximately 170°C. Above around 350°C, the particle emissions begin to increase again.

Sulphates form due to the sulphur content of the fuel (sulphur-oxygen compounds). The use of ULSD fuel contributes to a reduction in overall particle formation.

Diesel Particulate Filter

In order to combat PM emissions, a diesel particulate filter was developed in order to store and then “burn off” accumulated soot. The filter element of the diesel particulate filter consists of a ceramic honeycomb made of heat-resistant silicon carbide. It is up to 50% porous and has a platinum-based, catalytic coating.

The DPF will trap and store soot in the channels in the honeycomb structure. At certain intervals, the DPF will go through a “regeneration phase” to burn off the residual soot.

The high temperature generated by the exhaust heats the ceramic structure and allows the particles inside to break down (oxidize) into less harmful components.

■ Function of the DPF

The diesel particulate filter ensures the conversion of the following exhaust gas constituents:

- $C + 2NO_2 \Rightarrow CO_2 + 2NO$
- $C + O_2 \Rightarrow CO_2$
- $2CO + O_2 \Rightarrow 2CO_2$

The coating of the catalyst helps to achieve a reduction in the soot ignition temperature and thus to guarantee good regeneration characteristics of the diesel particulate filter.

The exhaust gases flow out of the oxidation catalytic converter and into the inlet ducts of the diesel particulate filter. These are closed at their ends. Each inlet duct is surrounded by four exhaust ducts.

The soot particles deposit on the platinum coating of the inlet ducts and remain there until they are combusted as a result of an increase in the exhaust temperature.

The cleaned exhaust gas flows out of the exhaust ducts through the platinum-coated, porous filter walls. Soot is only converted during vehicle operation under certain conditions such as full throttle situations. However, the optimum conditions are not always present in sufficient time intervals to remove soot, so a filter regeneration phase can be induced by the DDE periodically.

■ Filter Regeneration

The soot particles (carbon particles) that are deposited on the filter walls would eventually cause damage to the diesel particulate filter. The soot particles therefore need to be burnt off. This can happen when the exhaust temperature rises above the soot ignition temperature. This process occurs under certain vehicle operational situations or when the DDE initiates the process. This process is known as filter regeneration. The soot and carbon particles are converted to gaseous carbon dioxide (CO₂).

Soot particles have a relatively high ignition temperature. So, the exhaust temperature must be raised in order to initiate a regeneration phase. The exhaust temperature is raised by “post injection” events. The DDE system triggers the injectors after initial combustion has taken place. This raises the exhaust temperature, which in turn burns off the accumulated soot particles.

The DDE will initiate regeneration every 300 to 500 miles depending on several factors. Mostly, the regeneration is transparent to the driver. There may be a light loss of power for a short period while the soot is burned off.

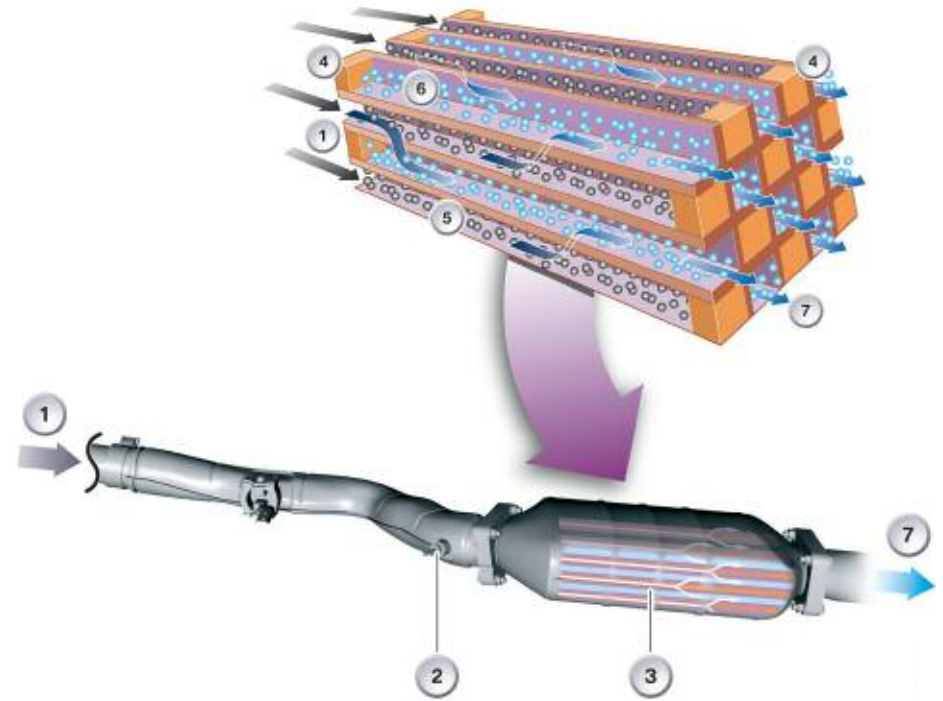

Index	Explanation	Index	Explanation
1	Exhaust gas from DOC with soot particles	5	Inlet channel
2	Exhaust gas temperature sensor	6	Outlet channel
3	Diesel particulate filter (DPF)	7	Cleaned exhaust gas without soot particles
4	End of filter element		

Note: Newer diesel vehicles incorporate the DOC and the DPF in the same housing.

Sensors - Exhaust System

Exhaust Temperature Sensor

The DDE requires the exhaust temperature for controlling regeneration of the diesel particulate filter. The exhaust temperature sensor is designed as an NTC resistor sensor (the resistance decreases as temperature increases).

■ Version with Two Exhaust Temperature Sensors

One exhaust temperature sensor is located upstream of the oxidation catalytic converter and the other upstream of the diesel particulate filter.

Temperature	Resistance	Voltage
-40°C	Approx 96 kOhms	Approx. 4.95 V
+/-40°C	Approx 30 k Ohms	Approx. 4.84 V
+ 100°C	Approx 2.79 k Ohms	Approx. 3.68 V
+ 800°C	Approx. 31.7 k Ohms	Approx. 0.15 V

An exhaust temperature in excess of 240°C is required for regenerating the filter. Initiating the filter generation procedure at temperatures below 240°C would produce white smoke caused by excess hydrocarbon (HC).

The exhaust temperature sensor upstream of the oxidation catalytic converter ensures the regeneration procedure is only enabled at temperatures above 240°C.

The exhaust temperature upstream of the diesel particulate filter is registered in order to control post-injection and therefore the exhaust temperature itself ahead of the diesel particulate filter.

Depending on the type of vehicle, the exhaust temperature sensor upstream of the diesel particulate filter sets a temperature between 580°C - 610°C based on the post-injection volume.

Three different types of sensors are used in the exhaust system. These sensors detect the exhaust temperature, exhaust backpressure and exhaust composition (oxygen sensor). The location and number of exhaust temperature sensors vary depending on the type of vehicle.

■ Exhaust System with One Exhaust Temperature Sensor

In line with the introduction of the oxidation catalytic converter and the diesel particulate filter in one housing, only one exhaust temperature sensor upstream of the oxidation catalytic converter was used.

The sensor upstream of the diesel particulate filter is replaced by a characteristic map in the DDE. Currently, however, a second exhaust temperature sensor is again used upstream of the diesel particulate filter as the characteristic map cannot provide the required degree of accuracy.

Note: The electrical supply line must not be subjected to a pulling force of more than 80 N. Sensors that have been dropped must not be used again.

Oxygen Sensor

More stringent exhaust emission limits have rendered necessary more accurate control of the exhaust gasses. The mean quantity adaptation (MMA) makes it possible to comply with the specified limits with a corresponding safety margin.

This is necessary as the emission limits must still be maintained despite component tolerances and operating influences.

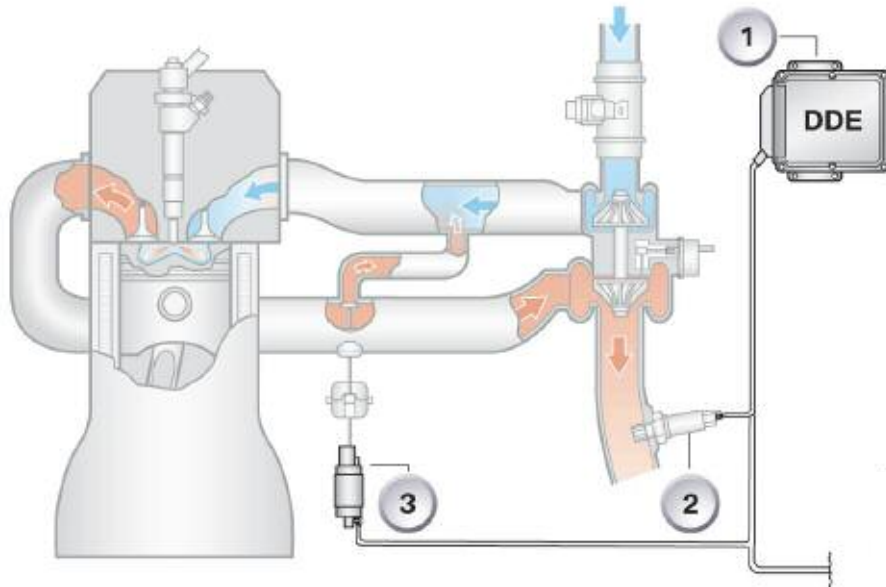

Index	Explanation
1	DDE
2	Oxygen Sensor
3	EGR Valve

With mean quantity value adaptation the fuel/air ratio (λ) is adjusted by corresponding adaptation of the exhaust gas recirculation. This feature compensates for any inaccuracies relating to manufacturing tolerances of the hot-film air mass meter or of the fuel injectors.

An injection volume averaged across all cylinders is calculated from the fuel-air ratio measured by the oxygen sensor and the air mass measured by the HFM. This value is compared with the injection volume specified by the DDE.

If a discrepancy is detected, the fresh air mass is adapted to match the actual injection volume by correspondingly adjusting the EGR valve, thus establishing the correct fuel-air ratio.

The MMA is not an "instantaneous" regulation but an adaptive learning process. In other words, the injection volume error is taught into an adaptive characteristic map that is permanently stored in the control unit.

The MMA characteristic map must be reset with the aid of the BMW diagnosis system after replacing one of the following components:

- Hot-film air mass meter
- Fuel injector(s)
- Rail-pressure sensor

For optimum combustion, a diesel engine is operated with a fuel-air ratio of $\lambda > 1$, i.e. rich in oxygen. $\lambda = 1$ signifies a mixture of 1 kg fuel with 14.7 kg air.

The oxygen sensor is located at the inlet to the shared housing of the diesel particulate filter (DPF) and oxidation catalytic converter.

The oxygen sensor used on the M57D30T2 is the Bosch LSU 4.9 broadband oxygen sensor. It is installed before the DPF and DOC.

Exhaust System Layout (Typical)

The following illustration is a representation of a typical exhaust system on a diesel vehicle. The exhaust system shown does not have a DPF and DOC in the same housing. Future US production vehicles will have a DPF and DOC in the same housing. Also, the vehicles will have an SCR system, and the SCR catalyst will be located at position (9).

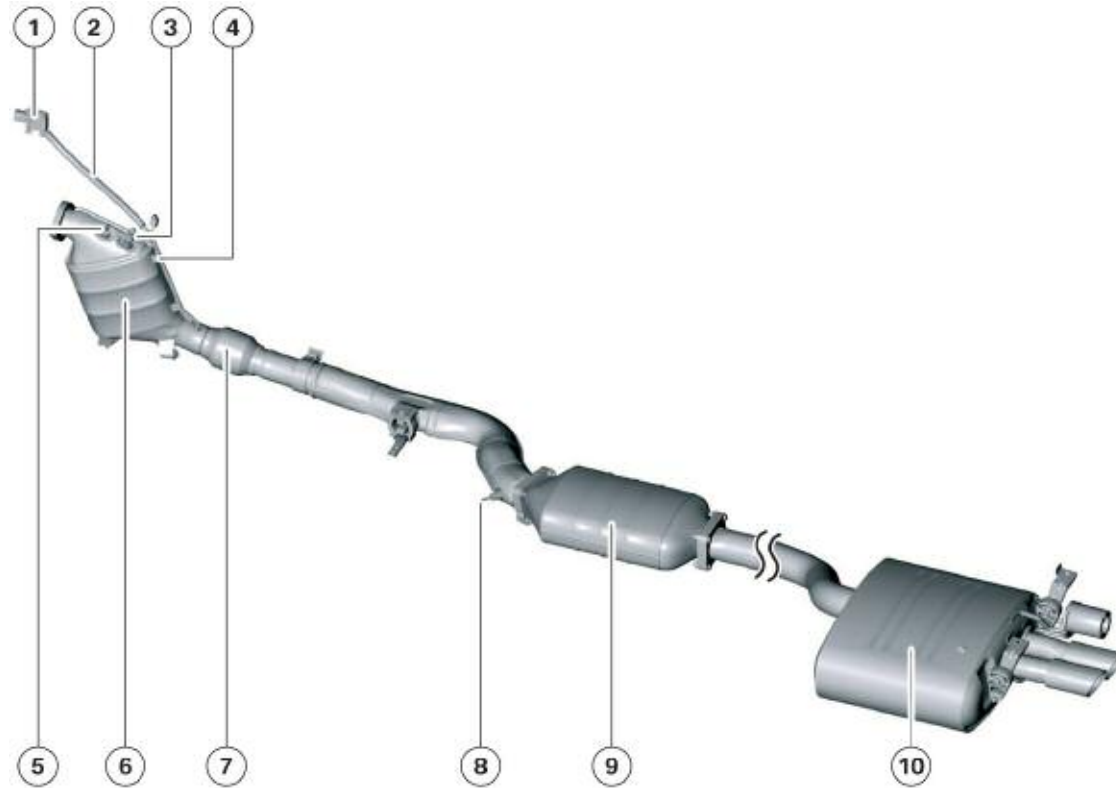

Index	Explanation	Index	Explanation
1	Exhaust gas backpressure sensor	6	Diesel particulate filter (DPF)
2	Connecting pipe	7	Decoupling element
3	Oxygen sensor	8	Exhaust temperature sensor (or SCR injection nozzle)
4	Oxidation catalyst	9	Intermediate silencer (or SCR catalyst on new vehicles)
5	Exhaust gas temperature sensor	10	Rear silencer

Selective Catalytic Reduction (SCR)

One of the latest methods to reduce NO_x emissions is the use of the new Selective Catalytic Reduction (SCR) system. SCR systems have been in use in the heavy trucking industry for a few years. Now, these systems have been adapted for use in passenger cars.

The SCR system uses a special NO_x reducing catalyst which works in conjunction with a special reducing agent. The reducing agent is injected into the exhaust during certain periods of engine operation to further reduce NO_x emissions.

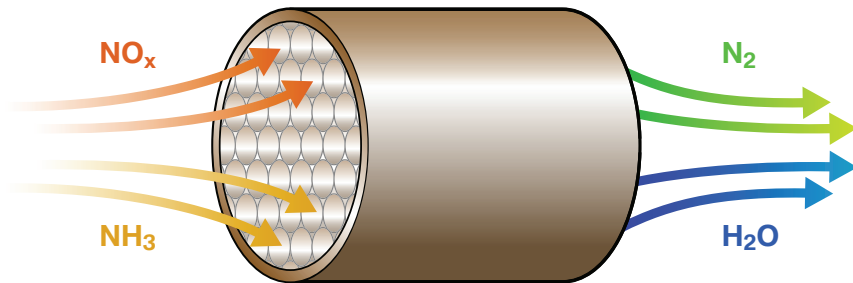

The reducing agent is a urea compound in an aqueous solution. Urea is an organic compound consisting of carbon, nitrogen, oxygen and hydrogen, with the formula $(\text{NH}_2)_2\text{CO}$. When introduced into the exhaust stream ahead of the SCR catalyst, a chemical reaction takes place.

The urea solution breaks down when injected into the exhaust stream. The resulting reaction decomposes into ammonia (NH_3) and carbon dioxide (CO_2). These substances enter the SCR catalyst to create a further reaction. The nitrogen oxides and ammonia entering the SCR catalyst are reduced into harmless nitrogen and water.

The SCR system consists of an on board system to store and inject the urea solution into the exhaust stream. The system works in conjunction with the DDE system to monitor NO_x in the exhaust stream to inject the urea accordingly.

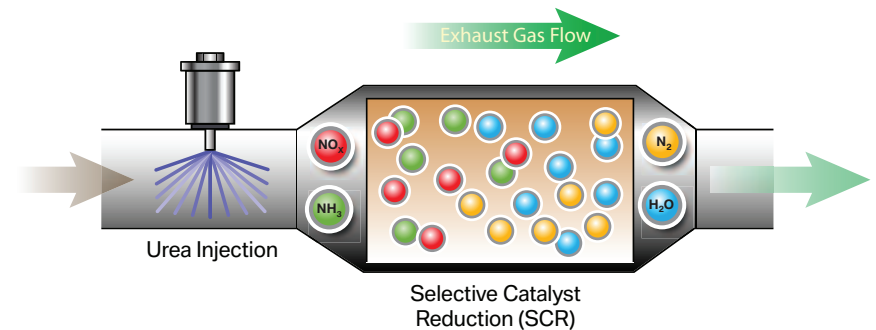

More information on the SCR system will be available in future training reference.

■ Diesel Exhaust Fluid

The diesel exhaust fluid is a urea based solution used as the reducing agent in the SCR system. It consists of a highly purified urea solution (32.5%) with demineralized water (67.5%).

Diesel Auxiliary Systems

As previously discussed, the combustion cycle of a diesel engine depends upon the heat of compression. However, when the ambient temperature is low, starting difficulties can occur due to several reasons.

The areas affected include the diesel fuel itself and the temperature of the combustion chamber. So, there are several systems in place to aid in cold weather starting.

These systems include the fuel heating system and the glow plug system. Also, the starter is modified to create sufficient RPM during cranking.

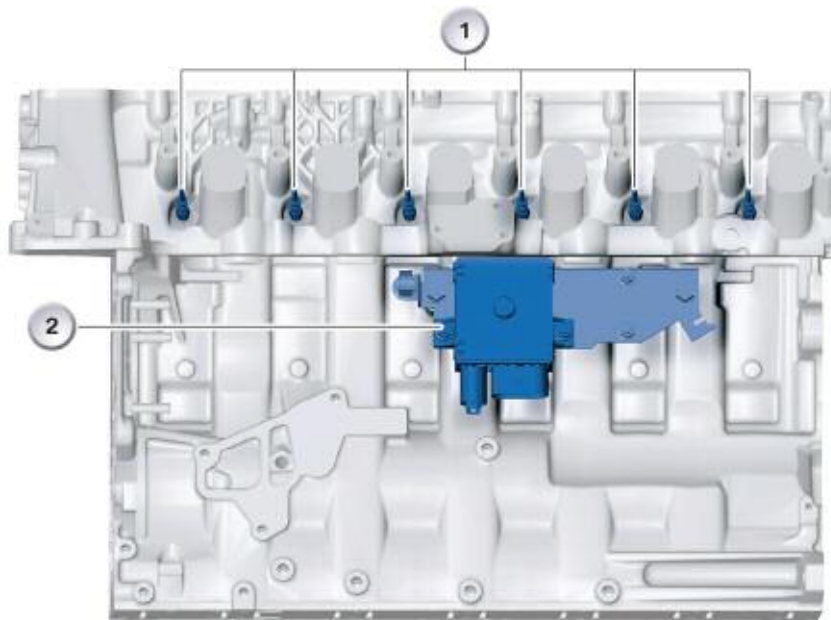

Index	Explanation
1	Glow plugs
2	Glow plug control module (GSG)

Glow Plug System

The glow plug system consists of electrically powered heating devices called glow plugs. These plugs are installed in the cylinder head with the tip of the plug extending into the combustion chamber. When starting the vehicle at low ambient temperatures, the glow plugs are energized and provide pre-heating for the combustion chamber.

This additional heat helps overcome the incoming cold air and improves the starting characteristics of the diesel engine.



Glow Plug System Function

Modern glow plug systems have several new features in comparison to the early cylinder pre-heating systems. These include:

- **Cylinder pre-heating** - Cylinder pre-heating is based on time and temperature. At moderate temperatures, the pre-heating time is reduced. In contrast, the time is increased at the engine temperature decreases. This information is obtained from the DDE. The glow plug system also monitors additional parameters from the DDE such as engine speed and injection volume. This additional data is used to de-activate cylinder pre-heating when not needed.
- **After-heating** - To reduce engine noise and emissions, the glow plugs can be used to maintain a constant even temperature in the combustion chamber. This activation is dependent upon engine temperature and engine speed.

Modern glow plug systems on BMW diesel engines consist of the following:

- Glow plugs
- Pre-heating control unit (on side of engine block)
- DDE (DDE supplies information such as engine speed, coolant temperature and injection etc.)
- Bi-directional data interface (BSD) from DDE to pre-heating control unit

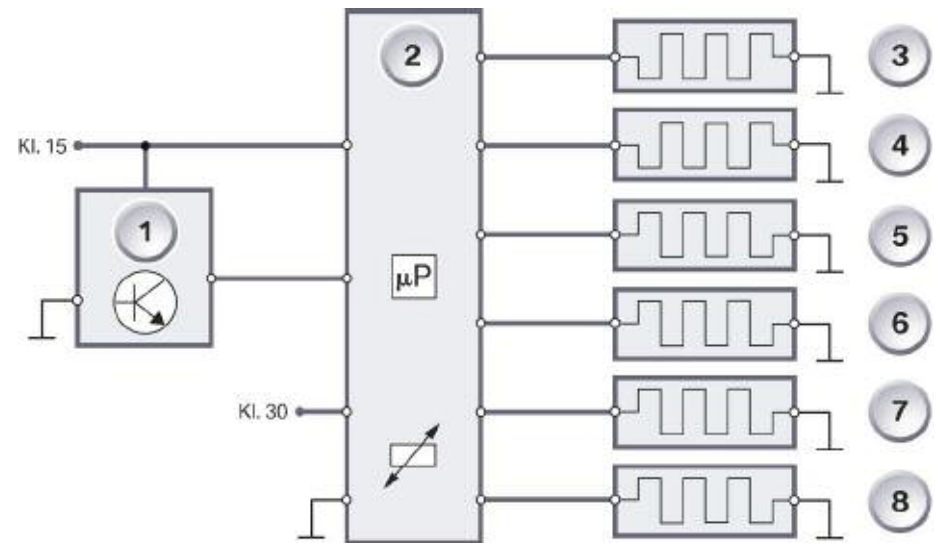

Diesel Starter

Diesel engines have a much higher compression ratio than gasoline engines and therefore require more torque when cranking. Since diesel engines rely on the heat of compression to run, there must be sufficient cranking speed when starting.

To provide sufficient torque, starters on BMW diesel engines are specially designed. The drive mechanism consists of a planetary gear set, to multiply torque in an efficient and compact manner.

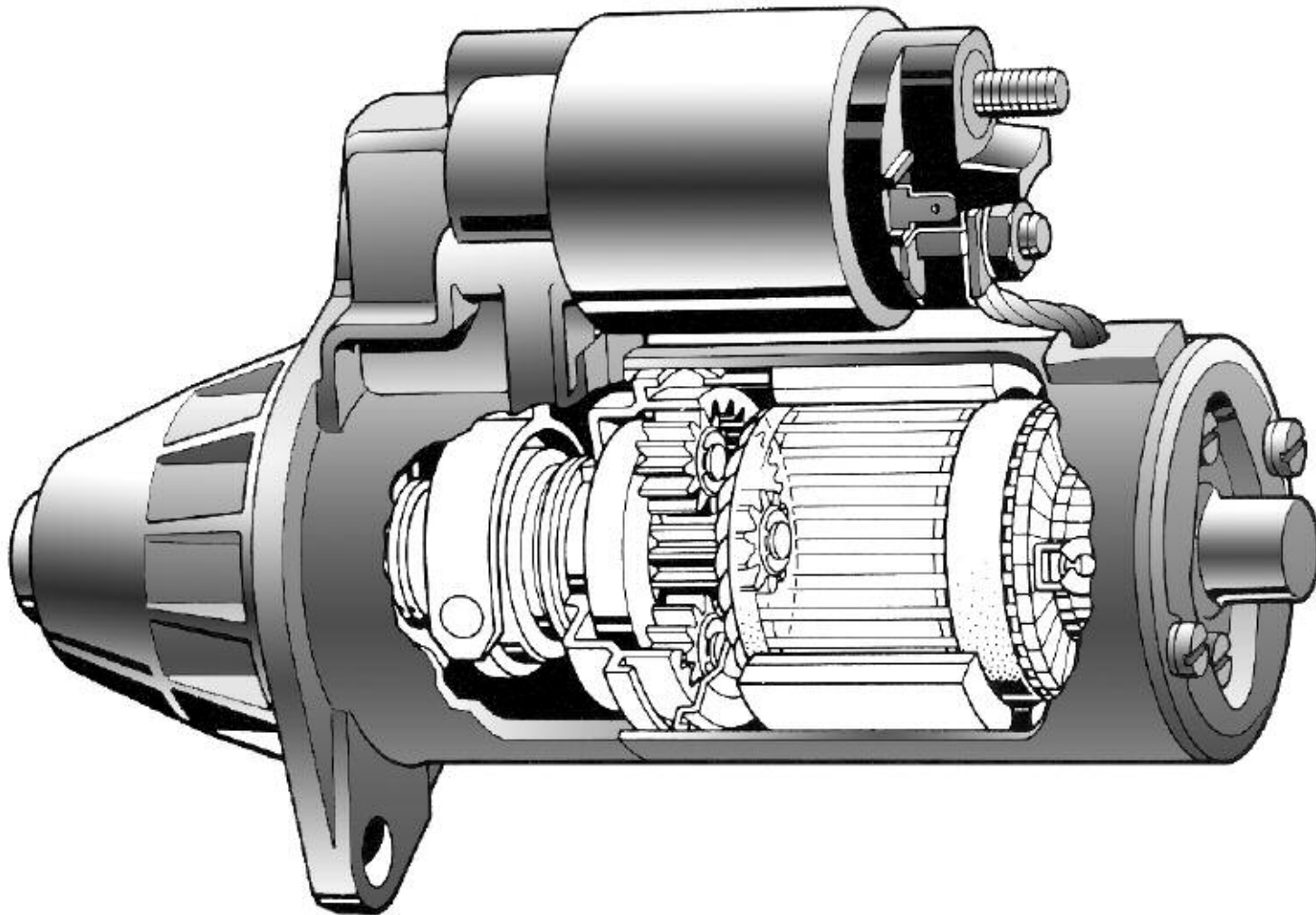

Vibration Reduction

Diesel engines have some inherent vibration concerns particularly during shutdown and startup phases. The engine mount control system provides a vacuum controlled motor mount system which can create a “hard” or “soft” setting based on engine and vehicle speed.

The motor mounts are controlled via a vacuum solenoid which is electrically controlled by the DDE.

Engine Mount Control

The engine mount control function of DDE actuates the electric changeover valve (EUV) for the variable-damping engine mounts.

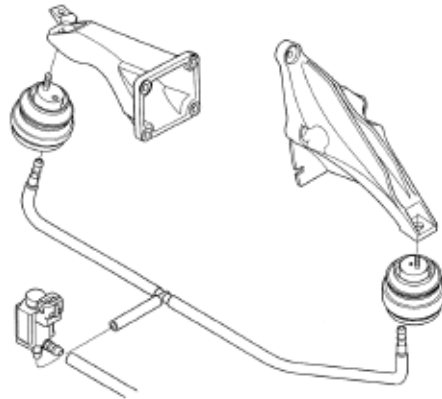

The engine mount is set to the "soft" setting for engine starts. When the start phase times out the engine mount changeover takes place as a function of operating point and with an engine-speed-related hysteresis and a road speed-related hysteresis.

The default position is the “hard” setting when no vacuum is present at the engine mounts.

Aside from engine speed and road speed, coolant temperature can also modify the RPM parameters between 1100 and 1200 RPM.

Activation of the damping-controlled hydraulic mounts by the DDE is based on the following parameters:

Engine Mount Function

	Switching value	Remarks
Engine speed	900 rpm	Hysteresis (+ 50 rpm)
Vehicle speed	60 km/h	Hysteresis (+ 5 km/h)

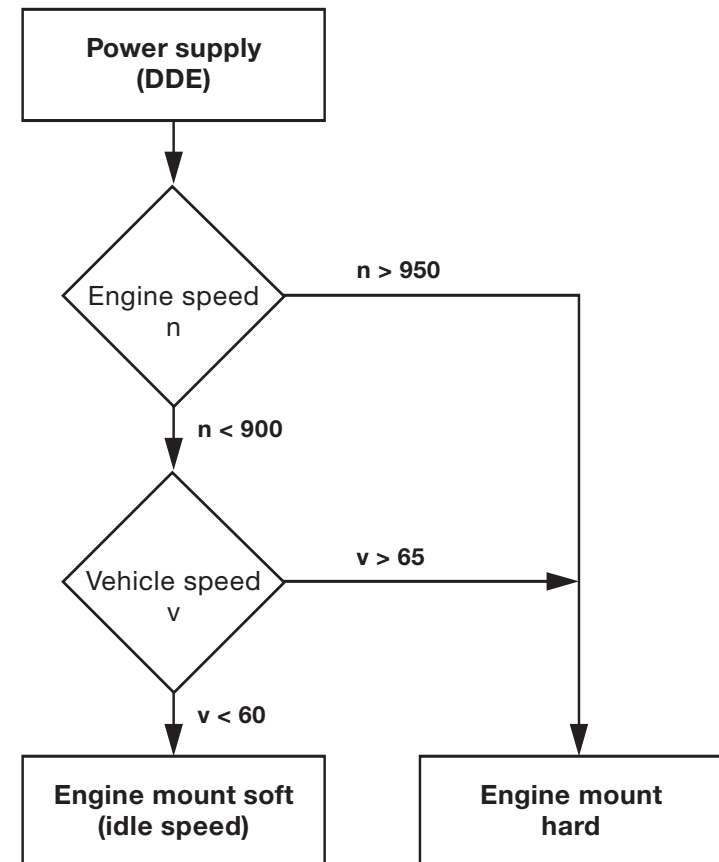



Classroom Exercise - Review Exercises

1. Where is the glow plug control module (GSG) located on the M57TU2 TOP engine?
 - A. Next to the JB
 - B. In the E-box
 - C. Under the intake manifold
 - D. On the bulkhead next to the air filter housing
 - E. In the left front wheel well

2. How does the glow plug control module communicate with the DDE?
 - A. via the BSD line
 - B. via PT-CAN
 - C. via LIN
 - D. via D-Bus
 - E. via Flex-ray

3. On the SCR system, a urea solution is injected into the exhaust stream. When the urea solution enters the SCR catalyst, the resulting reaction break the urea into carbon dioxide (CO₂) and:
 - A. H₂SO₄
 - B. NH₃
 - C. NO_x
 - D. N
 - E. O



Classroom Exercise - Review Exercises

4. Which of the following components, when replaced, does not require the MMA characteristic map to be reset with the BMW diagnostic system?
 - A. HFM
 - B. Fuel injector
 - C. Rail pressure sensor
 - D. Oxygen sensor

5. In the event of a swirl flap malfunction, what would be the possible symptom or complaint, when the swirl flaps are “stuck closed”?
 - A. Lack of high RPM power
 - B. Lack of low RPM power
 - C. High NO_x emissions at high RPM
 - D. High NO_x emissions at low RPM